



gandalf

**WIRING SYSTEM
DESIGN GUIDE**

Printed
in
Canada

LIMITATION OF LIABILITY

Gandalf Technologies, Inc. makes no warranty or representation, either express or implied, with respect to this documentation and its merchantability or fitness for any particular purpose. Gandalf Technologies, Inc. reserves the right to revise this publication and to change its content at any time, without obligation to notify any person or entity of such revisions or changes.

COPYRIGHT

This document and the subject matter thereon are proprietary items to which Gandalf Technologies Inc. retains an exclusive right to reproduction, manufacture and sale. This document is submitted in confidence for the use of the recipient alone, only in conjunction with Gandalf Technologies Inc. and its licensees, and for no other purpose unless permission for further disclosure is expressly granted in writing.

PRINTING INFORMATION

Manual number 4966G, Revision A0
First Edition, November 1987

To order additional copies of this manual, contact an authorized Gandalf dealer or your local Gandalf sales representative, and quote the manual number indicated above.

TRADEMARKS

™ Trademarks of Gandalf Technologies Inc. or its related companies.
® Registered Trademark of Gandalf Technologies Inc. and its affiliated companies.

Building a network distribution system is a task that requires careful planning and decision making. If you are involved in either the re-wiring of an existing building or the installation of a wiring system in a new building, a well-designed distribution network distribution system is the key to success. To provide a successful wiring system you will want:

- *Expandability
- *Easy installation and maintenance
- *Flexibility
- *Simplicity for additions and relocations of workstations
- *Vendor independence; selection of a vast array of products and vendors
- *Reliability; quality
- *Cost-effectiveness; good return on investment
- *Capability of integrating both voice and data
- *Physical interconnectivity

Your evaluation of a network distribution system will largely depend on the factors.

In a growing and more complex network, you will want to design and specify a wiring system that will remain cost-effective and easy to maintain as you expand.

The Gandalf Wiring System has been designed to enhance our networking products, as our customers have grown and the need to tie all systems together has become an important issue. This system is flexible and also compatible with other manufacturer's equipment or local networking schemes. It addresses all requirements of distribution from the building entrance to the subscriber's terminal. This wiring system and the subsequent literature has been developed in conjunction with MOD-TAP System, an independent company whose only product over the past ten years has been communications wiring.

The Gandalf Design Guide provides information on the design, specification, and installation of voice and data communications wiring. In addition, Section 8 provides component information and technical tips for the successful installation and maintenance of a Gandalf Communications Wiring System.

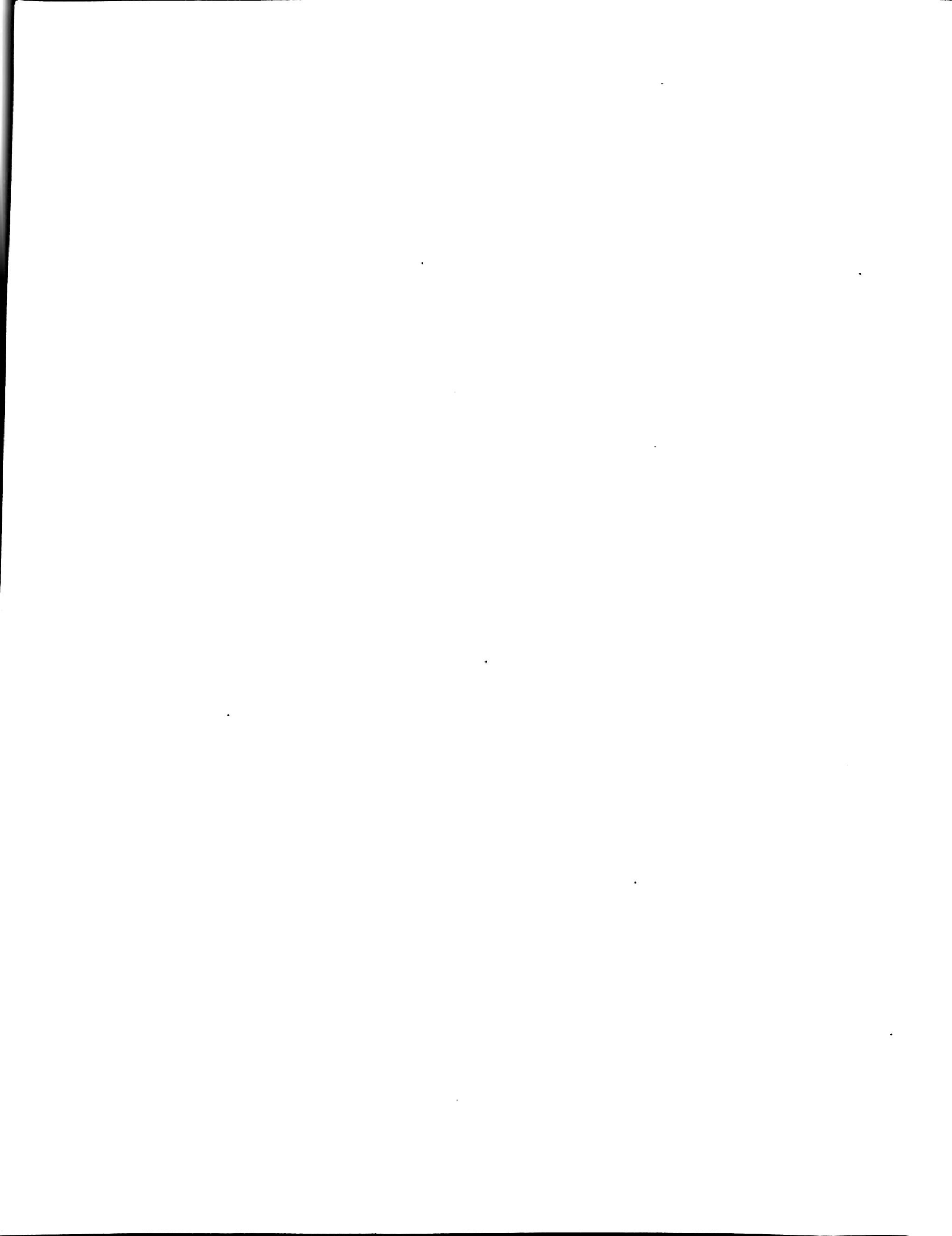

TABLE OF CONTENTS

66M Rack Mount Frame	05.06	Interface Adapter	
66M Wall Mount Frame	05.12	Drop Side	03.05
Adapters	07.02	System Side	04.04
Analog Signal	01.07	Line Cord	
Applications Catalog	08.01	Drop Side	03.05
BICX Wall Mount Frame	05.13	Normal/Reverse	03.07
Bandwidth	01.07	System Side	04.04
Bridging Clip	05.06	Local Area Network	01.10
Cable		Cable	01.11
Baseband	01.12	Drop Side	03.09
Broadband	01.12	Necessities	06.04
Coaxial	01.12	Node	01.11
Demountable Drop Run	03.03	Node at DstbnFrame	05.11
Feeder	02.03	SubLAN	01.11
Drop Side	03.03	System Side	02.04
Extension	04.06	Logical Section	05.03
System Side	04.06	MOD Patch	05.07
Fiber Optic	01.12	Patch Cords	07.03
Fixed Drop Run	03.04	MOD-FIT	05.07
Local Area Network	01.11	Modem	01.06
SubLAN	01.11	Modular Polarisation	
Trunk	05.09	Distribution Frame	05.08
Twisted Pair	01.12	Drop Side	03.06
Channel	01.07	System Side	04.05
Class ID	04.02	Multiplexer	01.06
Component Specs	07.01	Necessities	06.01
Computer	01.04	Network Interface	01.02
Connectors, Standard	02.07	Node, LAN and SubLAN	01.11
Considerations		Nomenclature	
Distribution Frame	02.05	Distribution Frame	05.14
EMI/RFI Compliance	02.05	Drop Side	03.10
FCC Registration	02.05	System Side	04.07
Fire Codes	02.05	Normal/Reverse	03.07
Shielding	02.06	Octopus	04.04
Consumables	06.02	Open Bay Rack	05.05
Cross Connect Wire	05.06	Rack Mount	
Cross Connects	05.15	66M	05.06
Cross Wye	04.04	Accessories	05.05
Data Switch		MOD Patch	05.07
Concentrated	01.05	MOD-FIT	05.07
Distributed (LAN)	01.10	Schedule 0 Color Code	03.11
Data Terminal	01.04	Shielding	02.06
Data over Voice	01.08	Signal	
Digital Signal	01.07	Analog	01.07
Distribution Frame	05.01	Digital	01.07
Considerations	02.05	Specifications	07.01
Logical Section	05.03	Standards	
Rack Mount	05.04	Color Code	03.11
66M	05.06	Connectors	02.07
Accessories	05.07	Modular Polarisation	02.07
MOD Patch	05.07	Drop Side	03.07
MOD-FIT	05.07	Frames	05.08
Wall Mount		System Side	04.05
66M	05.12	Sub Distribution	02.03
BICX	05.13	Drop Side	03.08
Drop Side	03.01	Local Area Network	05.11
Drop	02.02	System Side	04.07
Dedicated	03.06	When to Specify	02.03
Demountable	03.02	SubLAN	01.11
Fixed	03.04	Switch	
Growth Factor	03.05	Data Concentrated	01.05
Universal	03.06	Data Distributed (LAN)	01.10
Wires per	03.05	Data Voice Integrated	01.09
Drop Set		Voice	01.03
Data	03.05	System Equipment	04.01
Voice	03.05	Connects	04.04
EMI/RFI Compliance	02.05	Class ID	04.02
Equipment Class ID	04.02	Interface	04.03
Equipment Overview	01.01	System Side	04.01
FCC Registration	02.05	Telephone Set	01.02
Fire Codes	02.05	Terminations	
Feeder Cable		ConnectORIZED	05.02
Drop Side	03.03	Cutdown	05.02
Extension	04.06	Splice	05.02
System Side	04.06	Test Gear	06.02
Harmonica		Tooling	06.03
Dedicated	03.06	Trunk Cable	05.09
Drop Side	03.03	Drop Side	03.08
System Side	04.04	System Side	04.07
Universal	03.06	Voice Switch	01.03
Integrated Switch	01.09	Wall Mount 66M	05.12
Interface	01.07	Wall Mount BICX	05.13
Network Interface	01.02	Wires per Drop	03.05
System Equipment	04.03	Wiring Grid	02.01
		Work by Others	06.03

Some of the information presented herein may not be applicable outside of the USA.

Equipment Overview

Building Communications Wiring

Drop Side Specifics

System Side Specifics

Distribution Frame Specifics

Necessities

Component Specifications

Applications Catalog

1

2

3

4

5

6

7

8

SYMBOL LEGEND

System Equipment

 Network Interface

 Voice Switch

 Computer System

 Data Switch

 Modem

 Multiplexer

 Data over Voice Box

 Integrated Switch

Drop Equipment

 Telephone Set

 Data Terminal

 Integrated Terminal

Feeder Cable



Harmonica



Universal Polarisation



Voice Polarisation



Data Polarisation

Demountable Drops



Universal Polarisation



Voice Polarisation



Data Polarisation

Fixed Drops



Universal 2 Channel



Universal 4 Channel



Voice 2 Channel



Voice 4 Channel



Data 2 Channel



Data 4 Channel



Combination 1 Voice & 1 Data



Combination 2 Voice & 2 Data

Line Cord



Interface Adapter



Distribution Frame



Feeder Extensions



PC (male-feml)

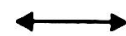

PP (male-male)



CC (feml-feml)

System Connects



General



Octopus



Cross Wye

Local Area Network (LAN)

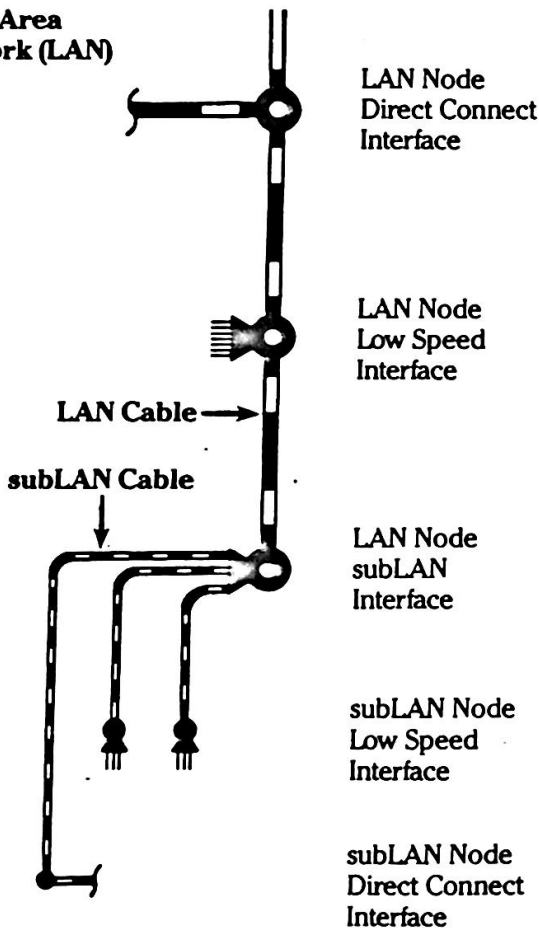



- 1.02 Basic Voice**
- 1.03 Voice Switch**
- 1.04 Basic Data**
- 1.05 Data Switch**
- 1.06 Modem and Multiplexer**
- 1.07 Definitions**
- 1.08 Data over Voice**
- 1.09 Integrated Switch**
- 1.10 Local Area Network (LAN)**
- 1.12 Cable**

1.02 Basic Voice

Telephone Sets are attached to Network Interfaces which serve as gateways into the Global Communications Network.

The Network Interface is the demarcation point between Network Company responsibility and Customer responsibility. It is normally furnished by the Network Company, one for each Network Line.

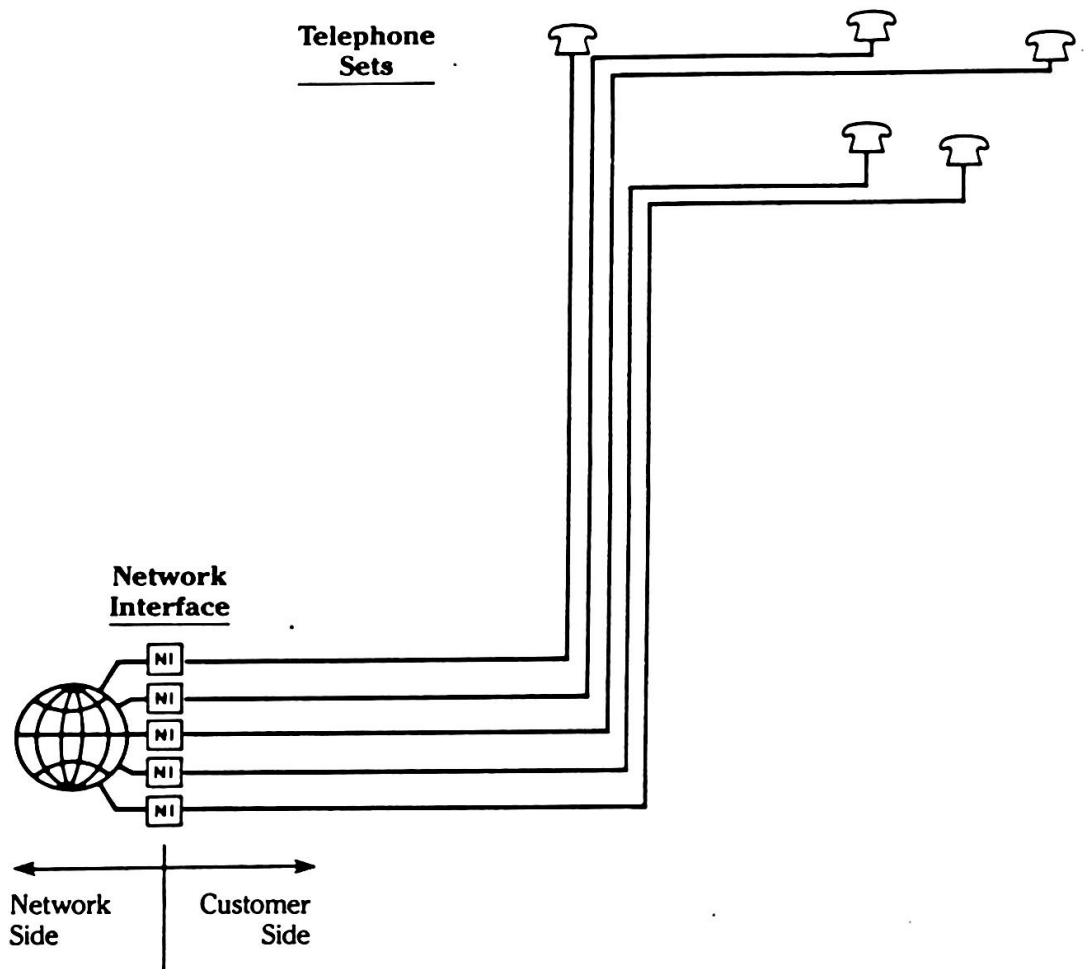

Voice Switch 1.03

The Customer Sides of Network Interfaces are attached to the NI Side of the switch.
Telephone Sets are attached to the Drop Side.

The switch dynamically interconnects attached devices.

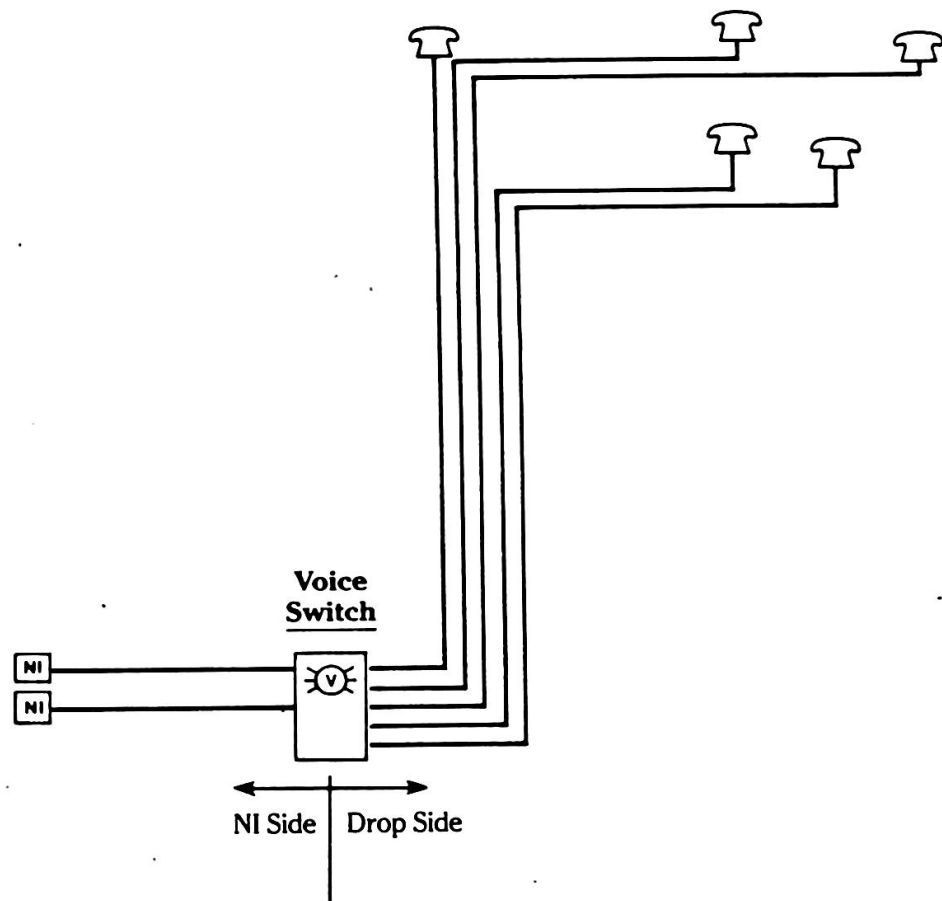

1.04 Basic Data

Data Terminals attach to a Computer System.

A Computer System processes and stores information.

A Data Terminal transmits and receives information. A smart Data Terminal also has some of its own processing and storage capabilities.

Data Terminals

Computer System

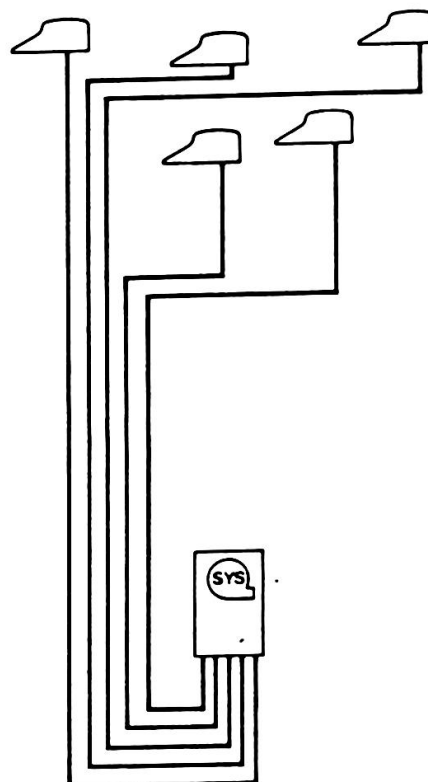

Data Switch 1.05

Computer Systems are attached to the System Side of the switch. Data Terminals are attached to the Drop Side.

The switch dynamically interconnects attached devices.

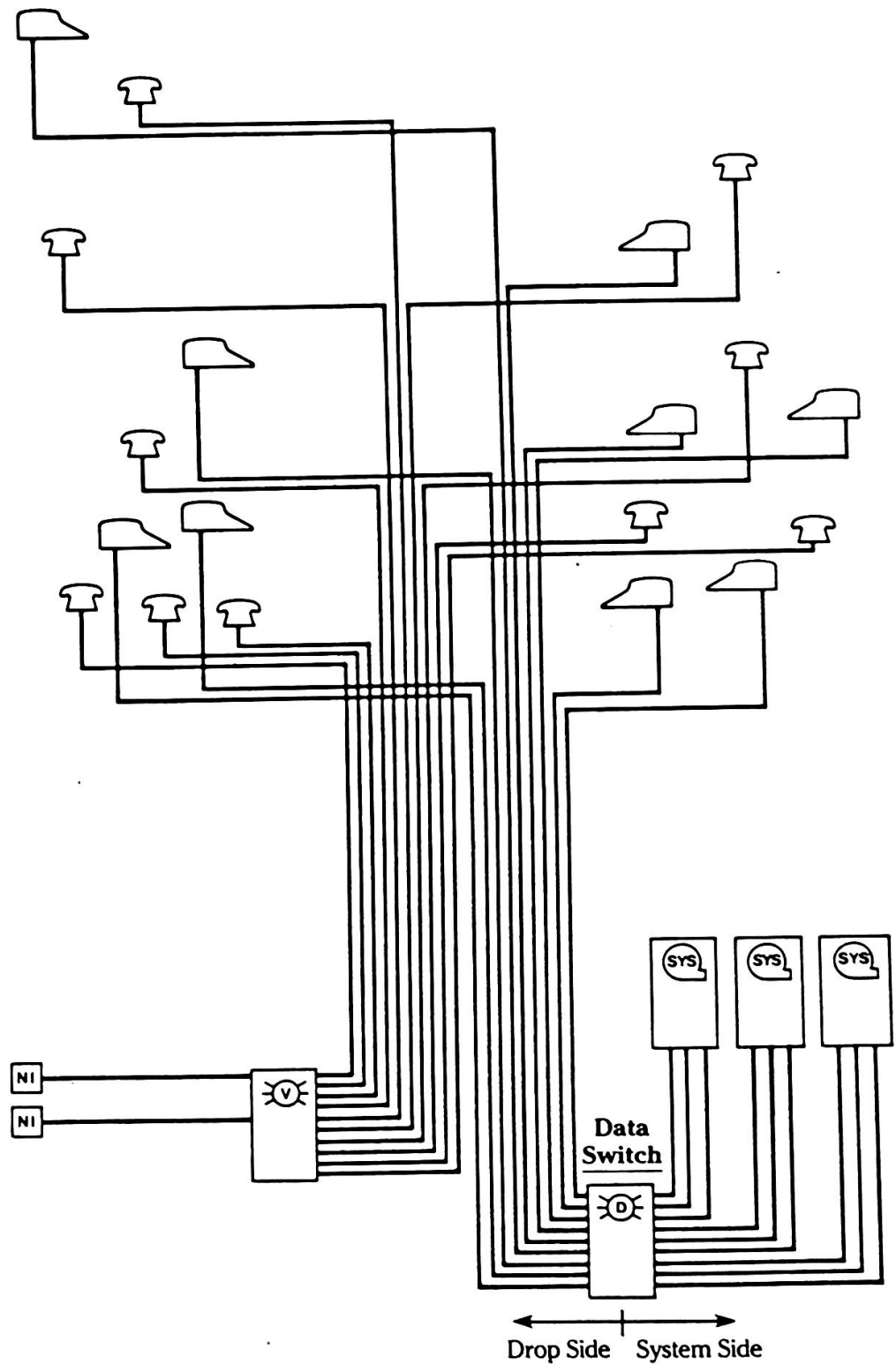

1.06 Modem and Multiplexer

Modems modulate a digital data signal for transmission over an analog voice channel. The Data Equipment is attached to the Digital Side of the Modem. The Network Interface is attached to the Analog Side. A Telephone Set is normally not required.

Multiplexers maximize available channel bandwidth by combining many low speed digital channels into one high speed digital channel.

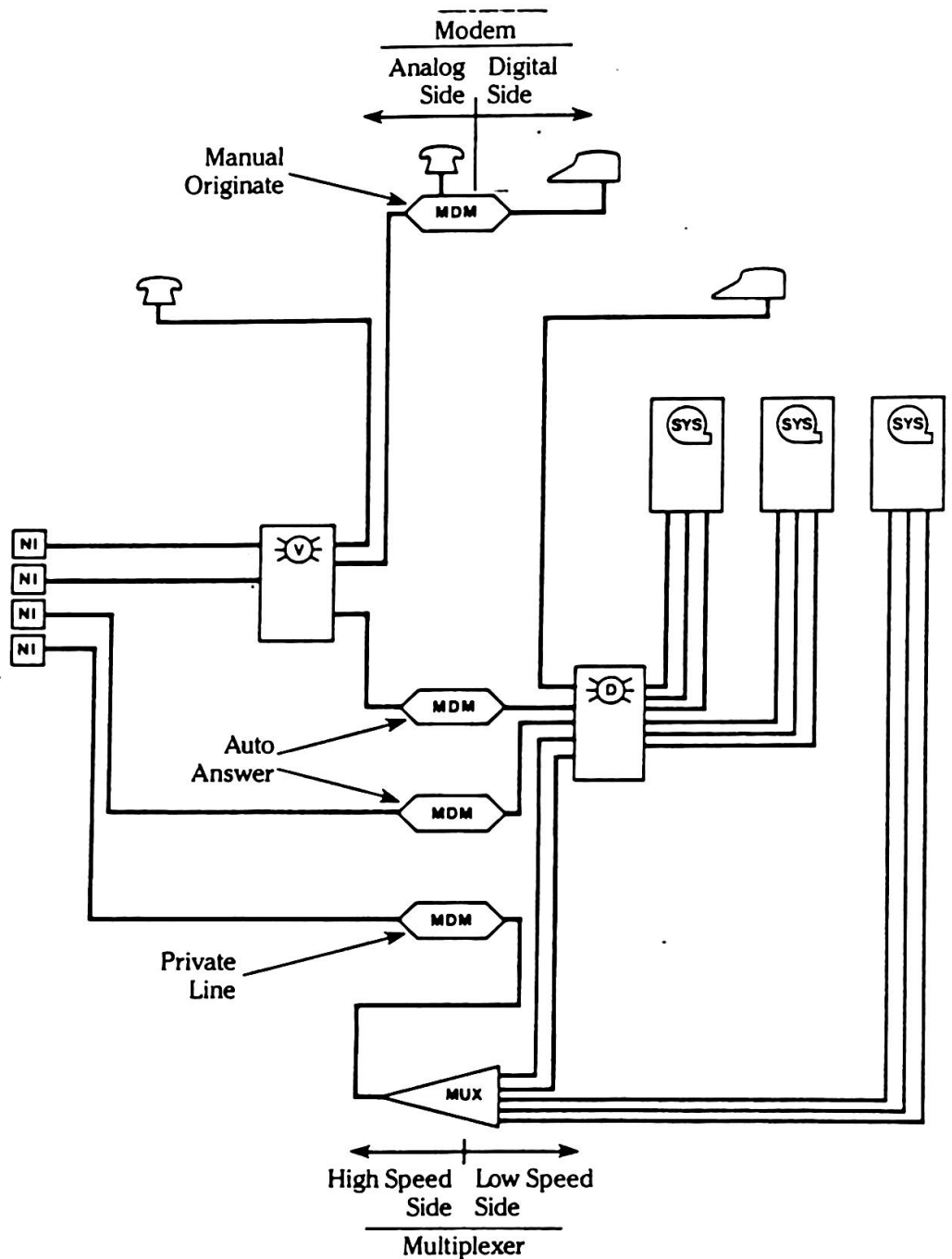

Definitions 1.07

Analog Signal

The signal may take on any value within a specified range. Voice Equipment is typically analog.

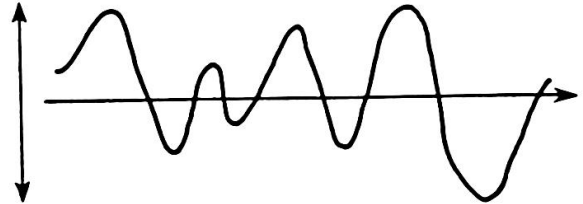

Digital Signal

The signal has only two states: 1 or 0. A segment of time is a bit. Data Equipment is typically digital.

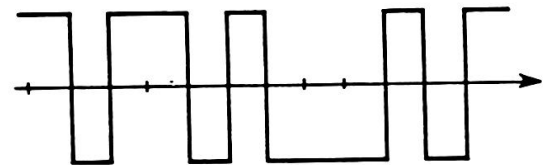

Channel

A channel is the information path between two devices.

Interface

The interface specifies the mechanical and electrical characteristics of an equipment's connection to a channel.

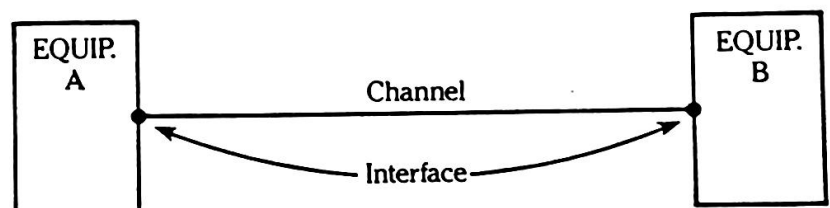

Bandwidth

The information carrying capacity of a channel usually expressed in bits per second.

1.08 Data over Voice

Data Over Voice (DOV) multiplexes a Telephone Set and a digital device over a common channel between DOV units.

The DOV units have three sides: DOV Drop, Data, and Voice.

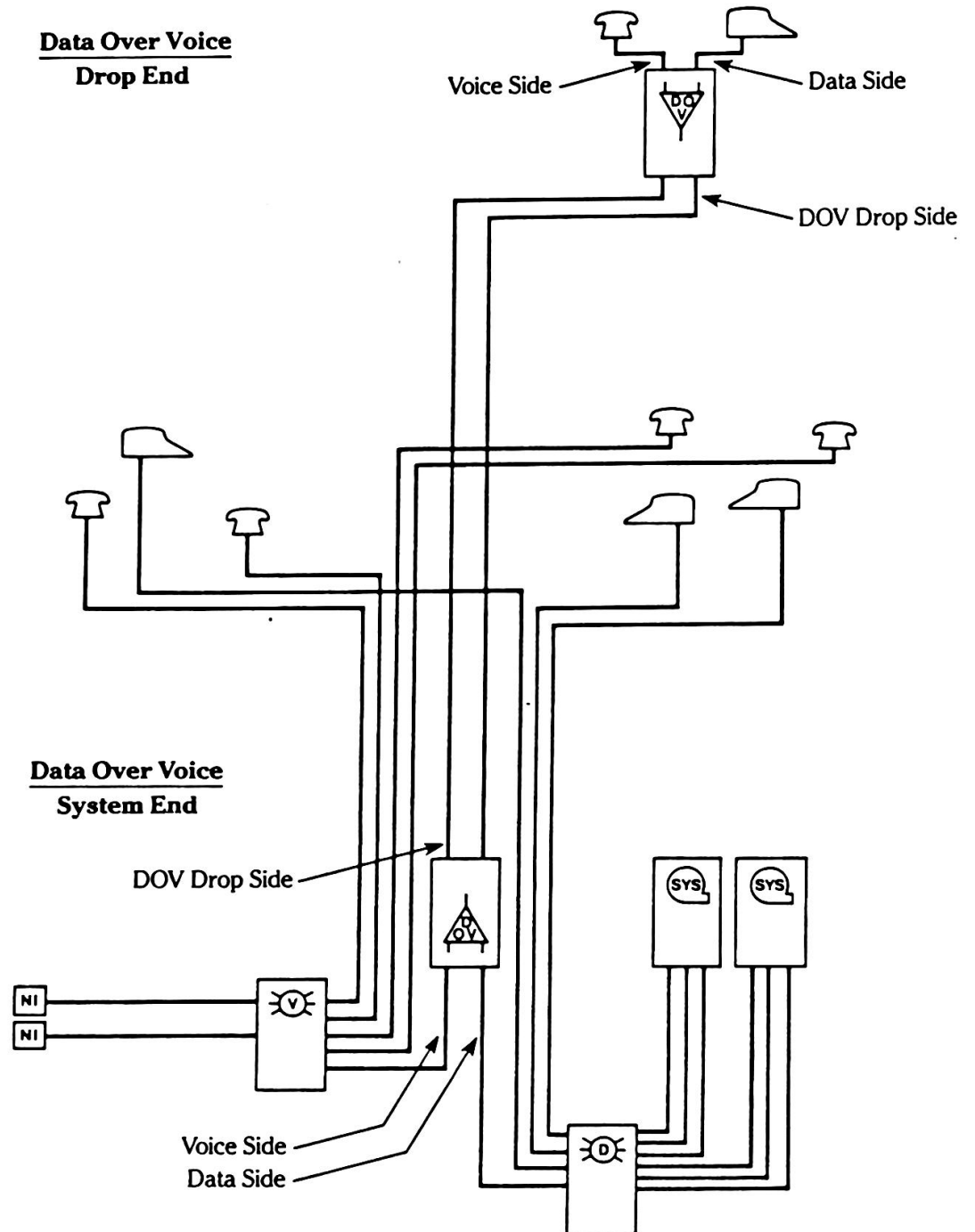

Integrated Switch 1.09

An Integrated Switch provides data and voice switching within a single unit. All digital data devices must attach through DOV multiplexing, either as Integrated Terminals (Data Terminal and Telephone in one unit) or with a DOV add-on.

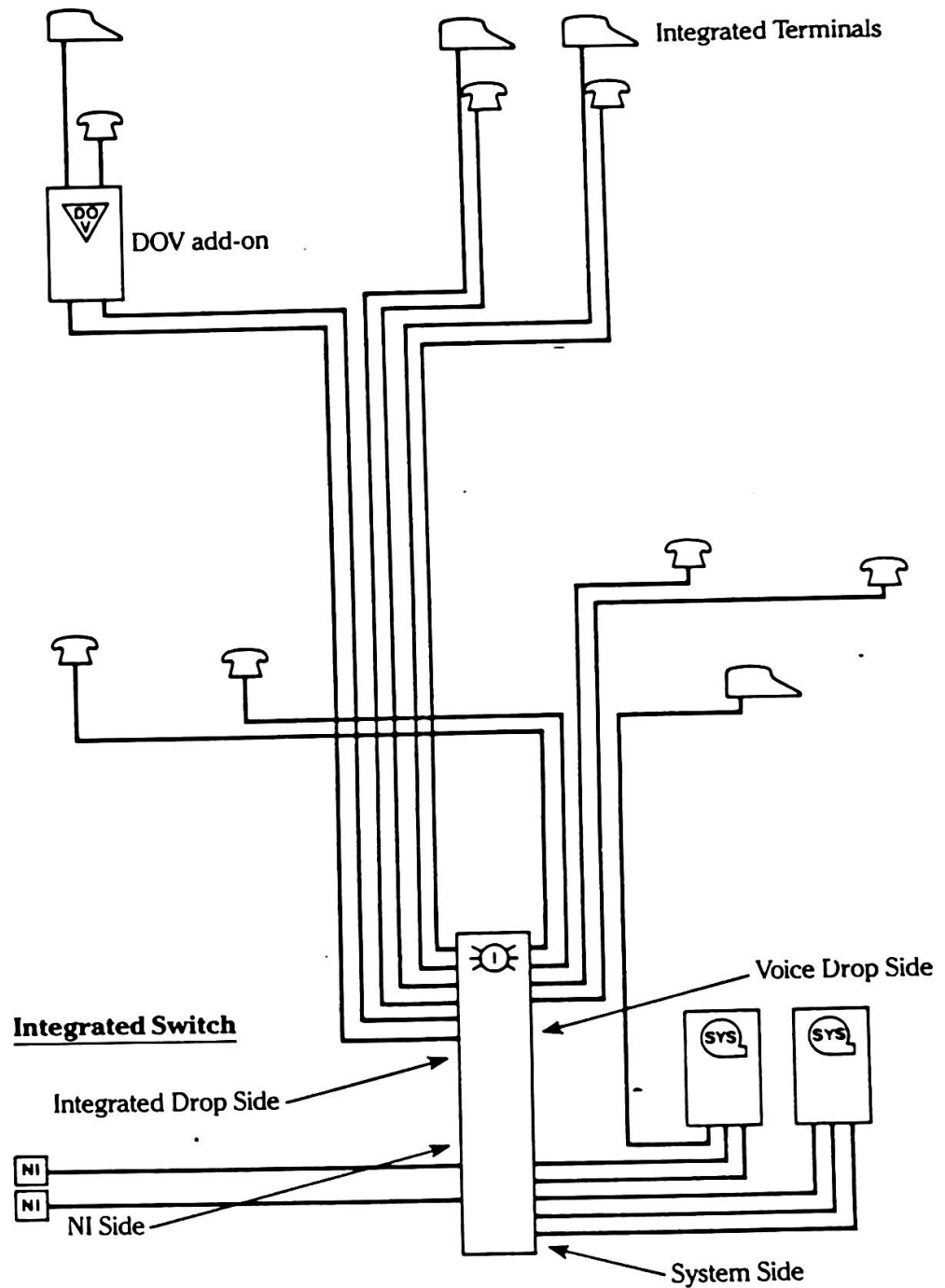

1.10 Local Area Network (LAN)

A Local Area Network combines multiplexing and switching functions to dynamically interconnect equipment attached at Nodes. It is a distributed Data Switch.

LAN with Star Topology

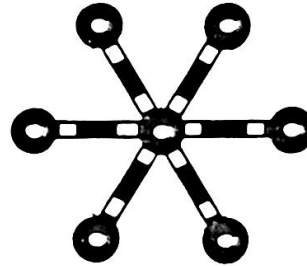

LAN with Ring Topology

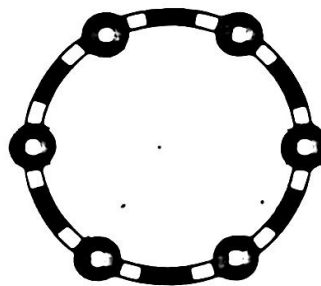

LAN with Bus Topology

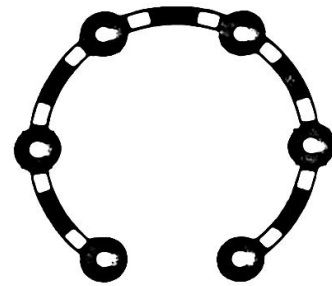

Bus LAN with Star subLAN

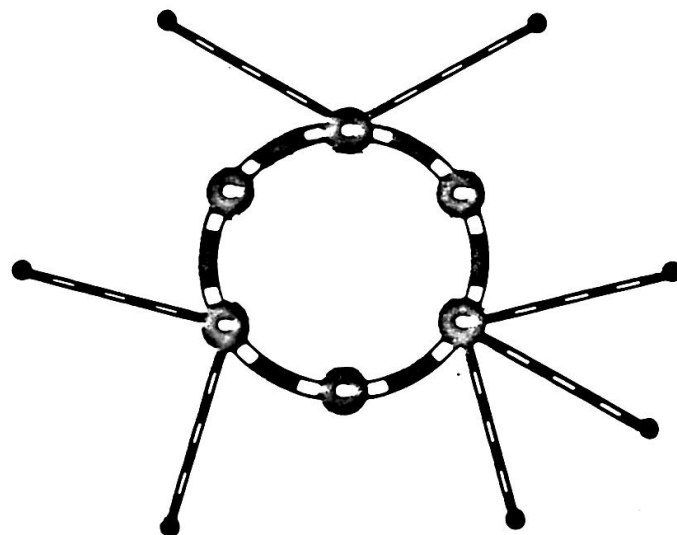

Nodes are attachment points to the LAN. LAN Direct Connect is the preferred interface.

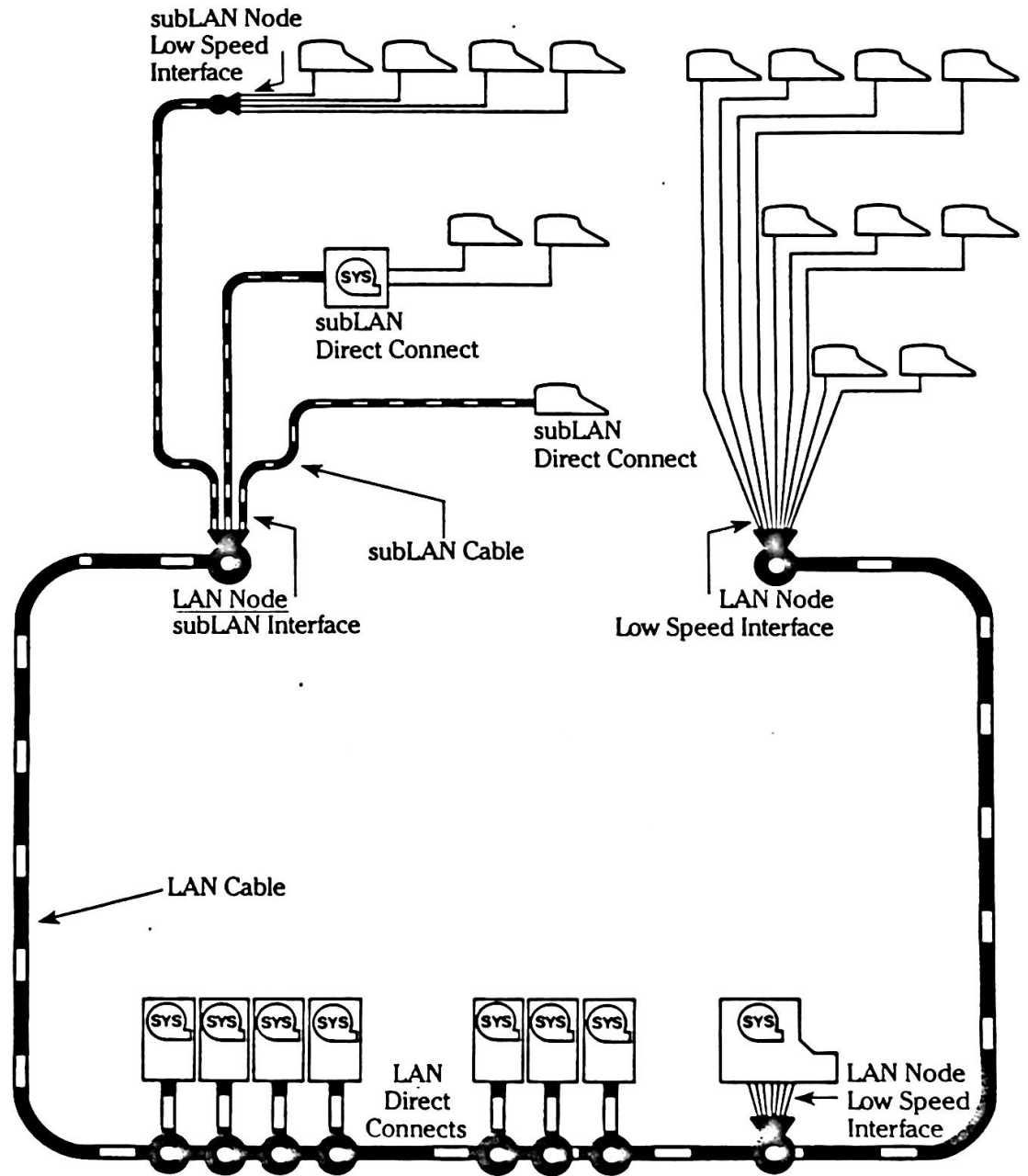

1.12 Cable

The type of cable to use will depend upon the equipment interface.

Twisted Pair

Telephone-type cable available in pair counts of 2 to 1200+. Up to 4 million bits per second (Mbps) bandwidth per channel depending upon application and interface.

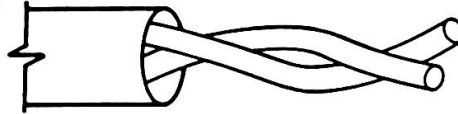

Coaxial Cable

10 Mbps per base band, broadband carries many base bands.

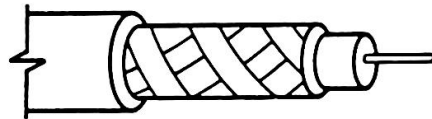

Fiber Optic

200 Mbps per fiber channel.

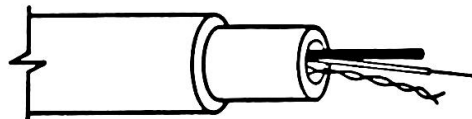

2.02 Basic Wiring Grid

2.03 Wiring Grid with Sub Distribution

2.04 Wiring Grid with Local Area Network

2.05 Distribution Frame Considerations

2.05 Regulatory Considerations

2.06 Shielding

2.07 Wiring Grid Standard Connectors



2.02 Basic Wiring Grid

All equipment is passively interconnected over twisted pair cable.

Drop Side Wiring Grid attachment points, called Drops, are provided for single channel equipment such as Data Terminals and Telephone Sets.

System Side Wiring Grid attachment points, called System Connects, are provided for multiple channel equipment such as Network Interfaces, Voice Switch, Data over Voice Master, Data Switch, and Computer Systems.

All cabling is terminated on the Main Distribution Frame (MDF). At the MDF any channel may be cross connected to any other compatible channel.

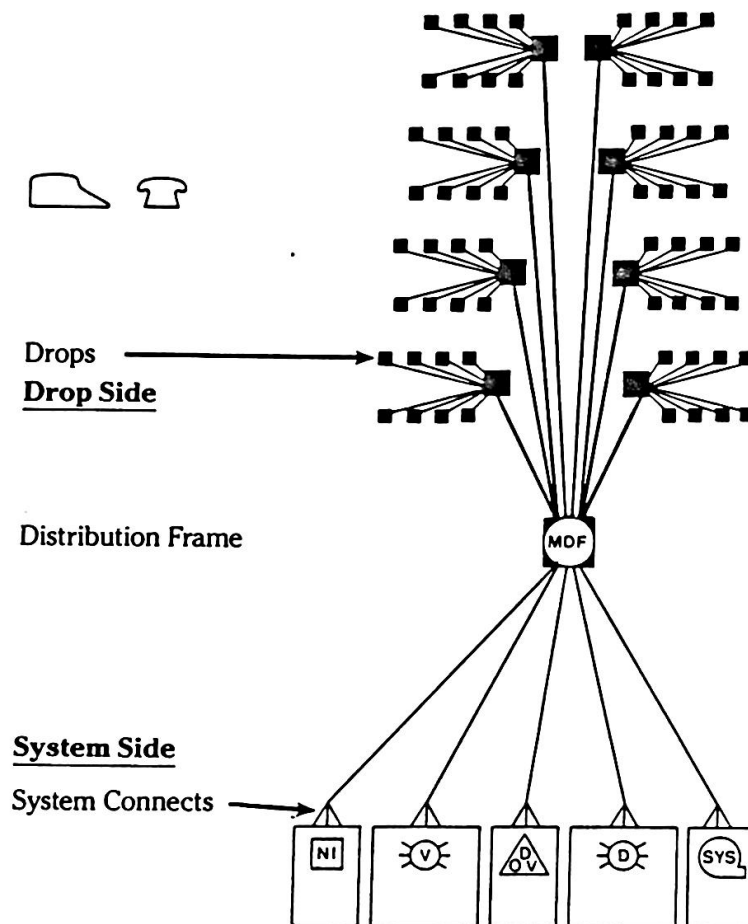

Wiring Grid with Sub Distribution 2.03

Sub Distribution is specified for large facilities where the cost of installing and maintaining an intermediate cross connect point is warranted by the savings that result from combining many Feeder Cables into one Trunk Cable.

The transition from Trunk Cable to Feeder Cables is made on a Sub Distribution Frame (SDF). Drop Side SDFs are usually installed in Utility Closets. System Side SDFs are installed in Equipment Rooms.

Sub Distribution should also be considered for facilities where there is a likelihood of a Local Area Network being added in the future. Locate SDFs at probable locations of LAN Nodes.

The SDF with the largest number of terminations is designated as the MDF. Trunk Cables run from the MDF to each SDF.

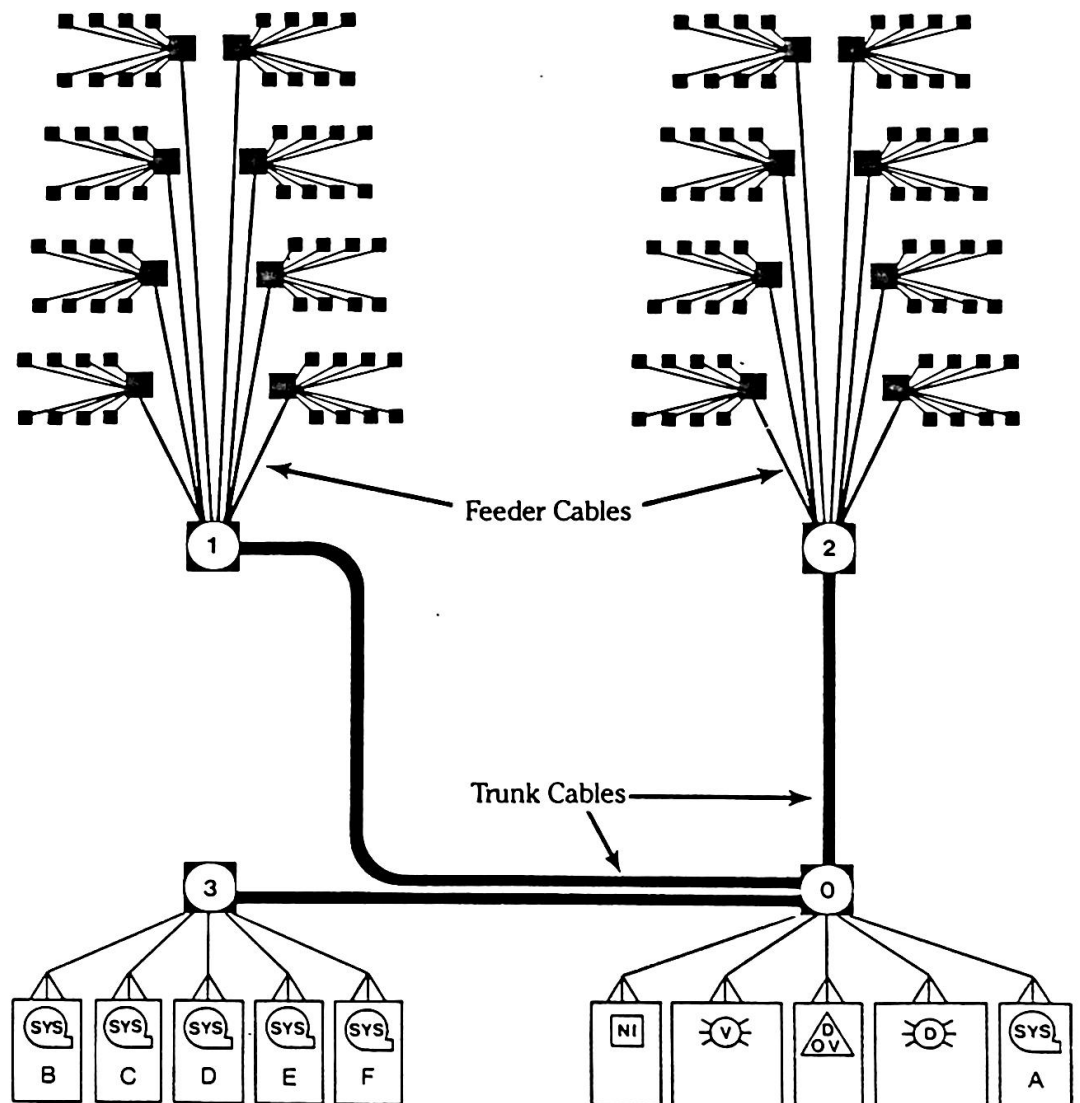

2.04 Wiring Grid with Local Area Network

A Local Area Network (LAN) consists of LAN Nodes interconnected over a LAN Cable. A LAN is a distributed Data Switch. LAN Nodes are attachment points to the LAN for equipment, either directly or via the Wiring Grid.

System Equipment attaches to the LAN through a LAN Node with Direct Connect Interface (i.e. SYSA, SYSC, SYSD, SYSE below) or through a LAN Node with Low Speed Interface (SYSF and DOV).

A Drop Side Data Terminal attached to the Wiring Grid can be cross connected at the SDF into a LAN Node with Low Speed Interface (SDF2). subLAN Nodes may also be used to provide either a Low Speed Interface or a subLAN Direct Connect Interface for drop equipment.

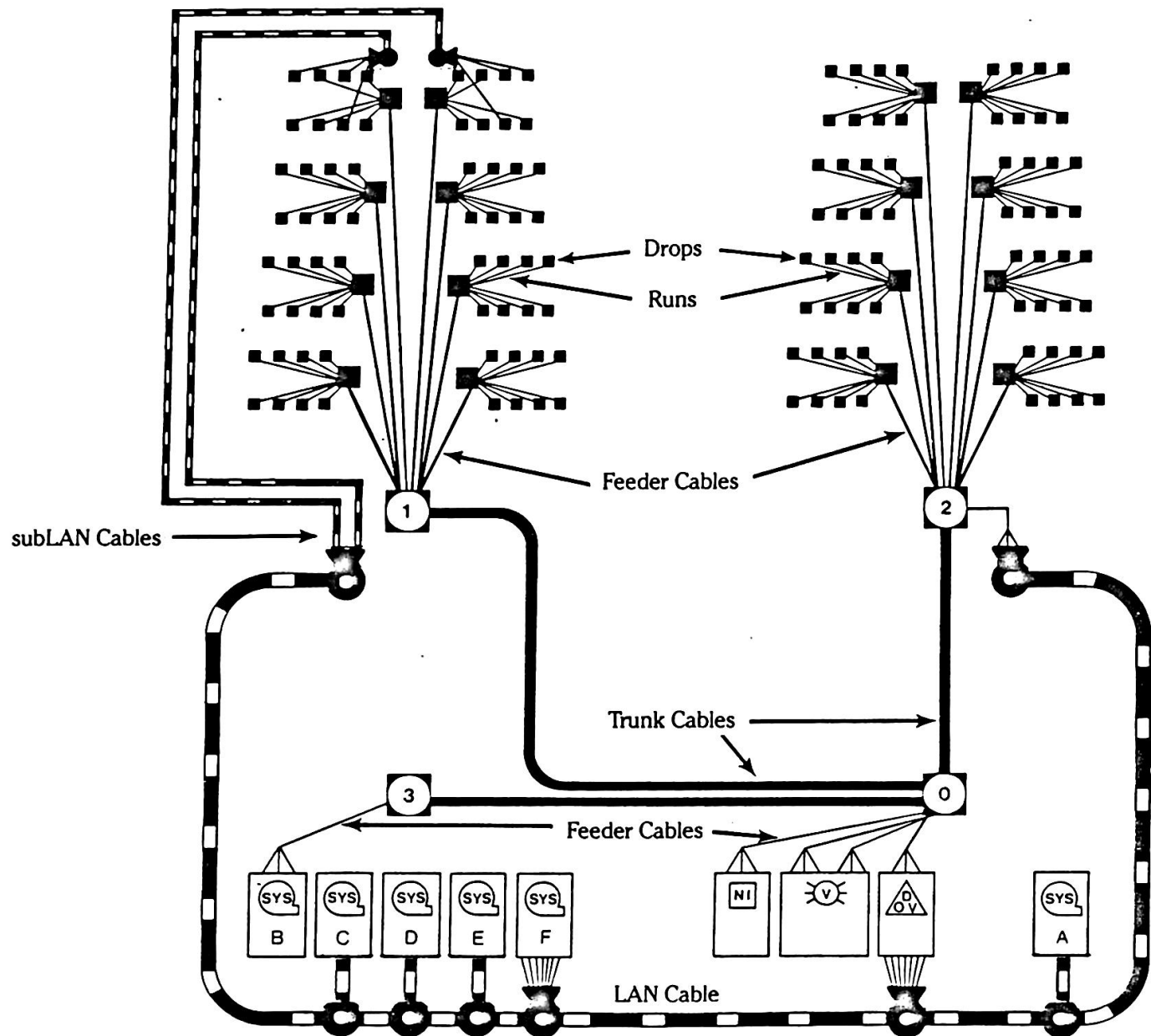

Distribution Frame Considerations 2.05

Distribution Frame requirements should be determined at the onset of a building's design process so that sufficient suitable areas are allocated. Long narrow areas are well suited for both wall mount and rack mount Distribution Frames.

The Distribution Frame should be bonded to building earth ground. Lighting and electrical convenience receptacles should be provided in the area.

If equipment is to be located at the Distribution Frame electrical and environmental requirements of the equipment must be considered.

Regulatory Considerations

Fire Codes

Cable and apparatus installed in forced air plenums must be of low smoke, low flame, fire retardant (FRD) composition or run in an approved raceway. Exceptions and alternatives may be available, consult the local fire marshal.

FCC Registration

Not applicable. "Electrically transparent adapters and extension cords used with telephone systems are not required to be FCC registered."

EMI/RFI Compliance

Normally not applicable. The FCC Rules Part 15 reads ". . . purpose [of these rules] is to limit radio [frequency] emissions emitted by computers [or other equipment]". The FCC does not propose to govern wiring external to the equipment unless that wiring is considered a part of that equipment.

IF FCC Compliance is required the wiring cable and apparatus together with the equipment they will be interconnecting must be tested and certified as a system.

2.06 Shielding

In practice not applicable.

Shielding of cables or apparatus will add little to the performance of a twisted pair Wiring Grid. The signals running through a twisted pair cable are as unlikely to cause interference to equipment (radios, tv, paging, etc.) as they are to be affected by nearby equipment (lighting fixtures, xray apparatus, etc.).

The limiting factor with twisted pair wiring is distance and speed limitations of some older interfaces, rarely noise.

Wiring Grid Standard Connectors 2.07

Multiple Channel 50position Plugs and Connectors

Standard telephone-industry 50position male plugs and female connectors are used at Feeder Cable ends. Convention is to have the male arrowhead pointing towards the Distribution Frame.

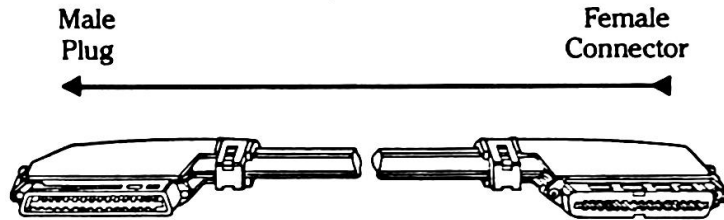

Single Channel Modular Plugs and Jacks

Western Electric (WECO or WE) and British Telecom (BT) modular polarisations are available. Circles below indicate which combinations mate.

Plug is male, jack is female.

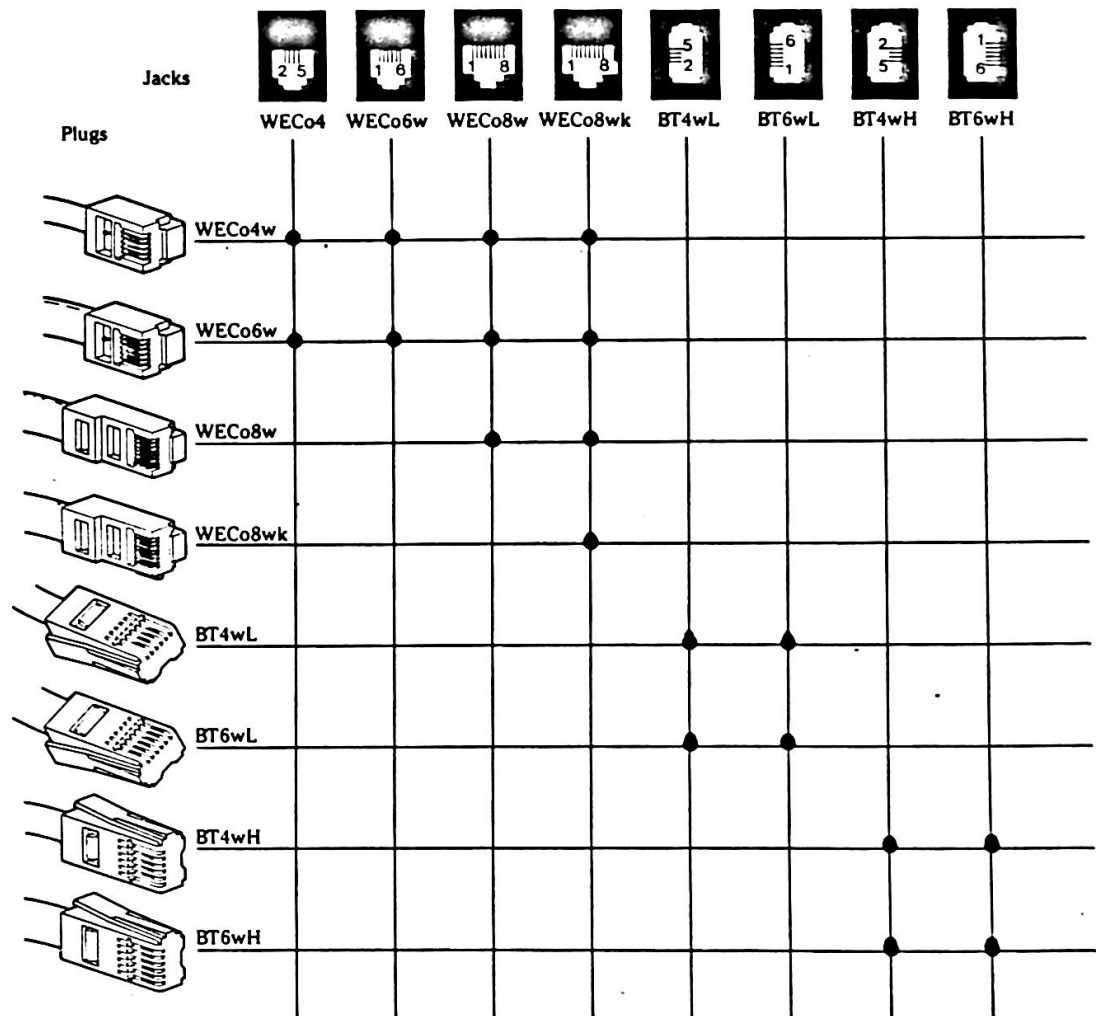

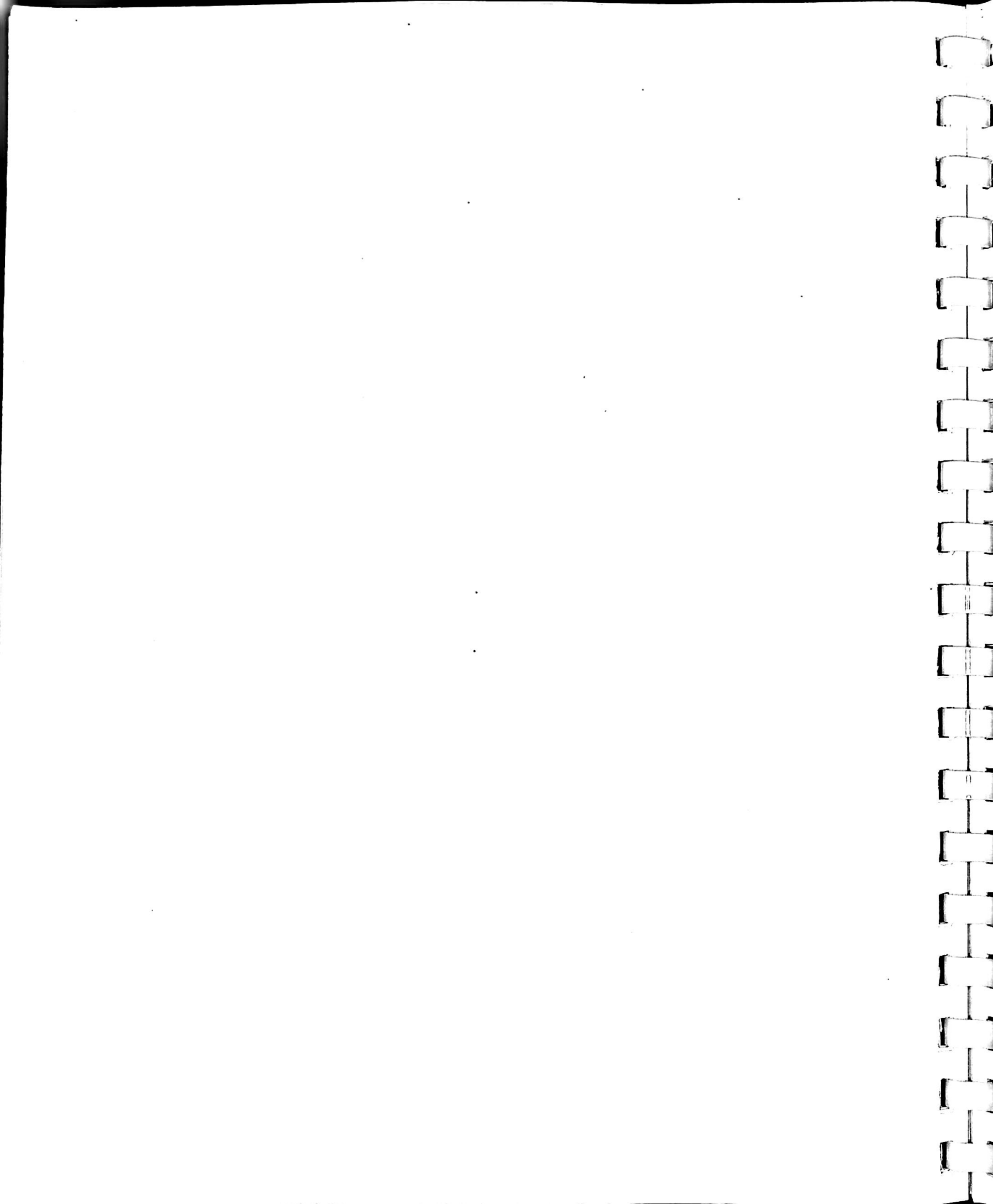

3.02 Drops

3.02 Demountable Drops

3.04 Fixed Drops

3.05 Drop Sets

3.05 Number of Wires per Drop

3.05 Demountable Drop Growth Factor

3.06 Modular Polarisation Combinations

3.07 Standard Drop Side Polarisation

3.07 Normal/Reverse

3.08 Sub Distribution

3.09 Local Area Network (LAN)

3.10 Nomenclature

3.11 Schedule 0 Color Code



3.02 Drops

Drops are single channel attachment points to the Wiring Grid. Equipment attached at Drops includes Data Terminals and Voice Telephone Sets.

Demountable Drops

Drops used with demountable partitions. The Grid and Equipment Sides of the Drop are factory wired with modular jacks.

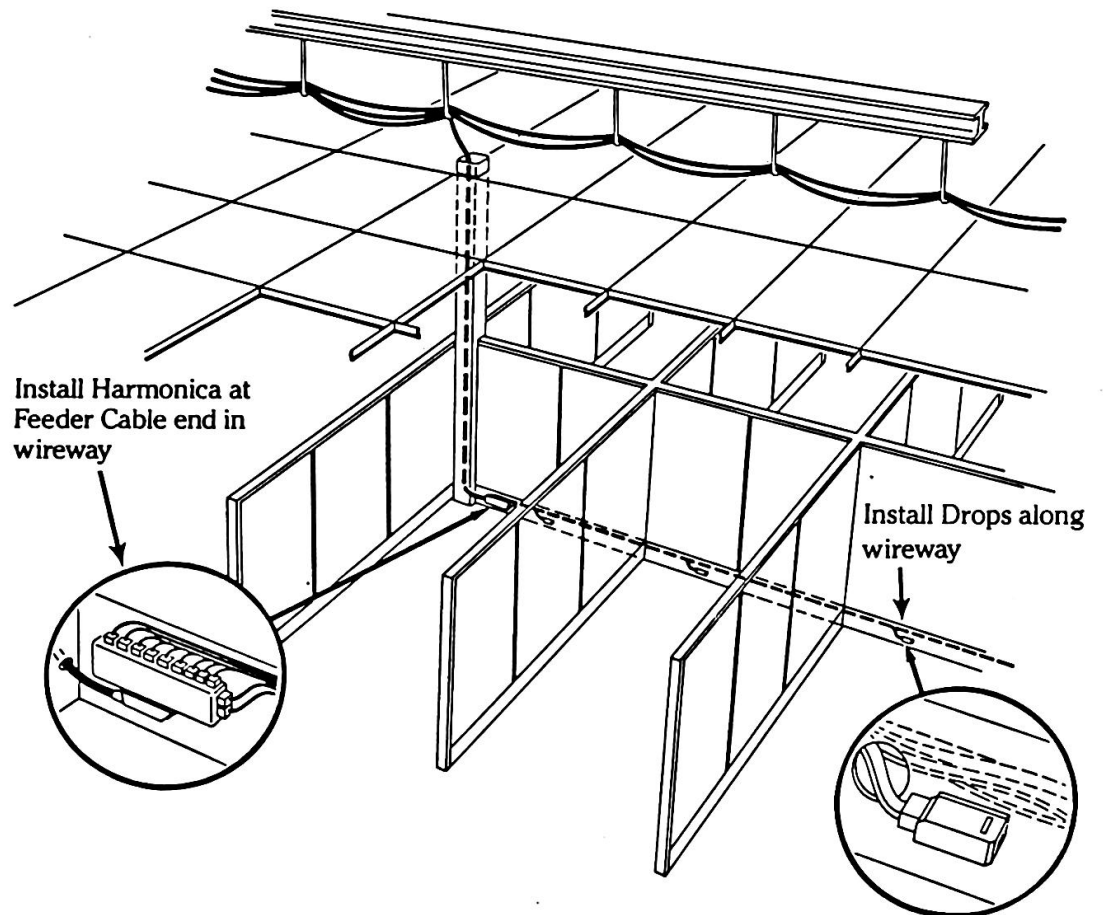

Demountable Drops 3.03

Demountable Drop Runs

Cables run from Demountable Drops to a Harmonica. Each end is field wired with modular plugs.

Harmonica

Transition from single channel Demountable Drop Runs to multiple channel Feeder Cable. Feeder Side 50position male plug is factory wired to Drop Side modular jacks.

Feeder Cables

25pair Inside Wire Cable (IWC) run from Harmonica to Distribution Frame. Harmonica end is field wired with a female 50position connector. Distribution Frame end is field wired with a 50position male plug.

Distribution Frame

Either Main Distribution Frame (MDF) or a Sub Distribution Frame (SDF). If SDF, a Trunk Cable is run from the SDF to the MDF.

Feeder Cable Routing

Standard routing for Drop Side Feeders is overhead in ceiling plenum from Distribution Frame to Power Pole, down Power Pole and into the demountable partition wireway.

If the ceiling plenum is forced air use FRD insulated and jacketed IWC cable. If the ceiling plenum is open air use PVC insulated and jacketed IWC cable.

Underfloor alternates include floor duct, cellular floor, trench-header, and raised access floor. Poke-through from floor below may also be used.

Undercarpet alternate requires special Feeder Cable approved for the application used under removable carpet tiles.

Demountable Drop Run Routing

Standard routing is within a wireway integral to the demountable partition from Harmonica to Drop. PVC Modular Cord is used.

Alternate is overhead in ceiling plenum. If plenum is open air use PVC modular cord. If plenum is forced air use FRD IWC Cable (2-, 3-, and 4-pair). Other alternates include underfloor (PVC Modular Cord) and undercarpet (cable approved for the application).

3.04 Fixed Drops

Drops used with fixed partitions. Equipment Side of Drop is factory wired with a modular jack. Grid Side has provision for field termination of Fixed Drop Run.

Fixed Drop Run

6 or 12pair Inside Wire Cable (IWC) run from Fixed Drops to Distribution Frame. Field terminated at both ends.

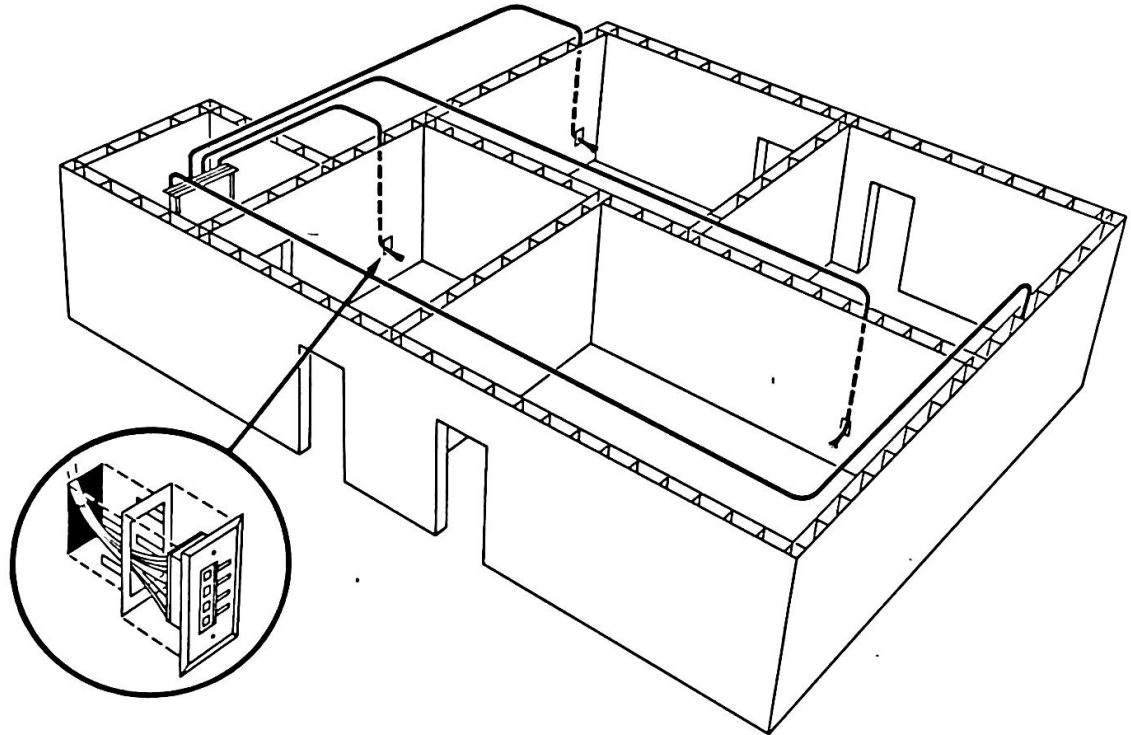

Fixed Drop Run Routing

Standard routing is overhead in ceiling plenum from Distribution Frame to fixed partition, down partition hollow to a lgang recess mounting. Alternate for solid wall is down the surface of the partition to a lgang surface mounting.

If the ceiling plenum is forced air use FRD insulated and jacketed IWC cable. If the ceiling plenum is open air use PVC insulated and jacketed IWC cable.

Drop Sets 3.05

A Drop Set includes all apparatus required to attach an equipment channel to the Equipment Side of a Drop.

Voice Drop Set

Typically consists of a Line Cord, factory wired with modular plugs at both ends.

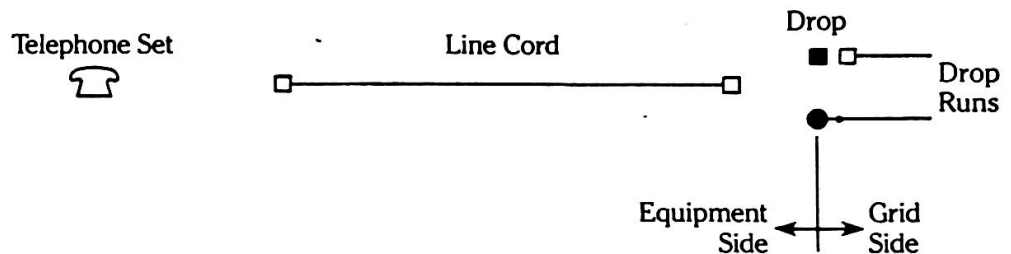

Data Drop Set

Typically consists of a Line Cord, factory wired with modular plugs at both ends and an Interface Adapter. The Interface Adapter has a modular jack factory wired to a D-type 25size, or other, equipment connector.

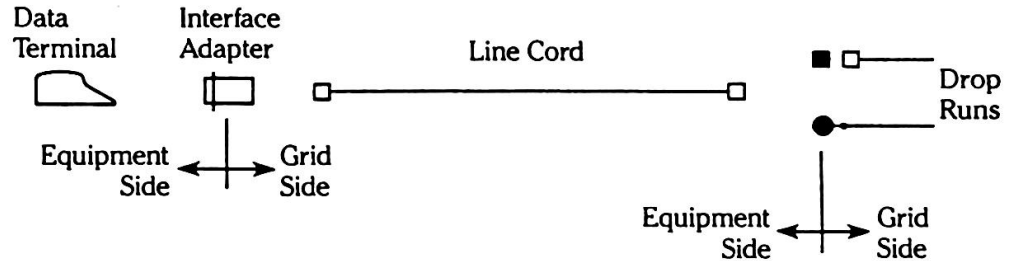

Number of Wires per Drop

Standard is 4 wires per drop (4w Drops).

6-wire and 8-wire are available as alternates.

Cable	Number of channels		
	4w	6w	8w
4-wire Modular Cord	1		
6-wire Modular Cord		1	
8-wire Modular Cord	2		1
6pair IWC	3	2	1 +
12pair IWC	6	4	3
25pair IWC	12	8	6
100pair IWC	48	32	24
600pair A/D	288	192	144
1200pair A/D	576	384	288

Demountable Drop Growth Factor

At initial layout time it is good practice to allow spare channels in each Drop Side Feeder Cable.

Standard factor is 50% growth. With 4w Drops allow 4 spare channels in each Feeder Cable. With 6w Drops allow 3, with 8w Drops allow 2.

3.06 Modular Polarisation Combinations

Universal Drop/Universal Harmonica

All Drops have the same Equipment Side modular polarisation. Any equipment can attach to the Wiring Grid at any Drop. This same modular polarisation is also used on the Grid Side of demountable Drops, at demountable Drop Run ends, and on Harmonicas.

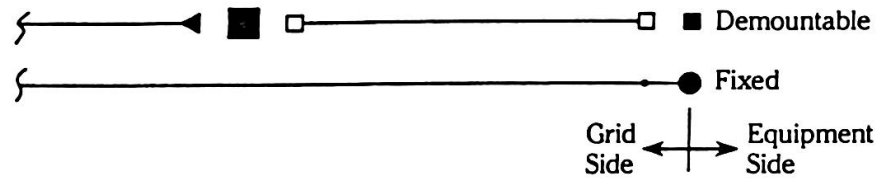

Dedicated Drop/Universal Harmonica

Each Drop is designated as either Voice or Data. Modular Polarisation on the Equipment Side of the Drop is different for each. Typically a modular combination is selected which would make it impossible to attach a Data Drop Set's modular plug to a Voice Drop's modular jack. The Grid Side of Demountable Drops, as well as Demountable Drop Run ends and Harmonicas have a universal modular polarisation.

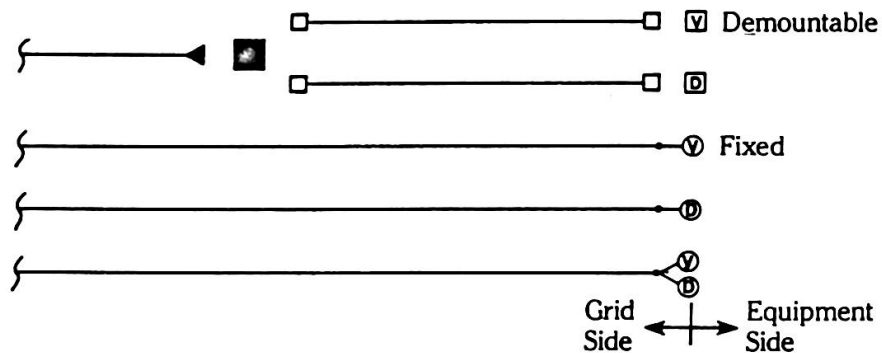





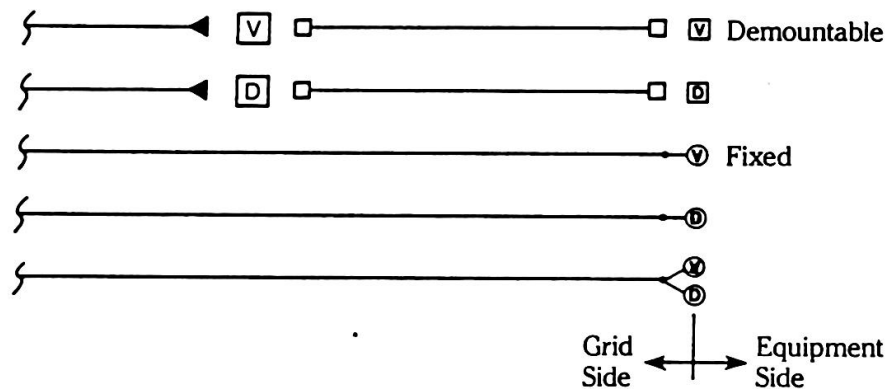













Dedicated Drop/Dedicated Harmonica

In this case Drop Side Feeder Cables are designated as either Voice or Data. A Voice polarisation is used on a Voice Harmonica, Voice Drop Run, Voice Drop, and Voice Drop Set. A different Data polarisation is used on a Data Harmonica, Data Drop Run, Data Drop, and Data Drop Set.



Standard Drop Side Polarizations 3.07

		Drop Grid Side			Drop Equipment Side		
		4w Drops	6w Drops	8w Drops	4w Drops	6w Drops	8w Drops
		Universal Drop Universal Harmonica	Voice				
Data	WECO4w		WECO6w	WECO8w	WECO6w	WECO8w	
Dedicated Drop Universal Harmonica	Voice						
	Data	WECO4w	WECO6w	WECO8w			
Dedicated Drop Dedicated Harmonica	Voice						
	Data						

Normal/Reverse

Modular cord and plugs may be assembled with either Normal or Reverse wiring. Normal is used throughout the wiring grid for Data. If Reverse is required for Voice then a Reverse Line Cord should be specified as the Voice Drop Set, all other wiring would remain Normal.

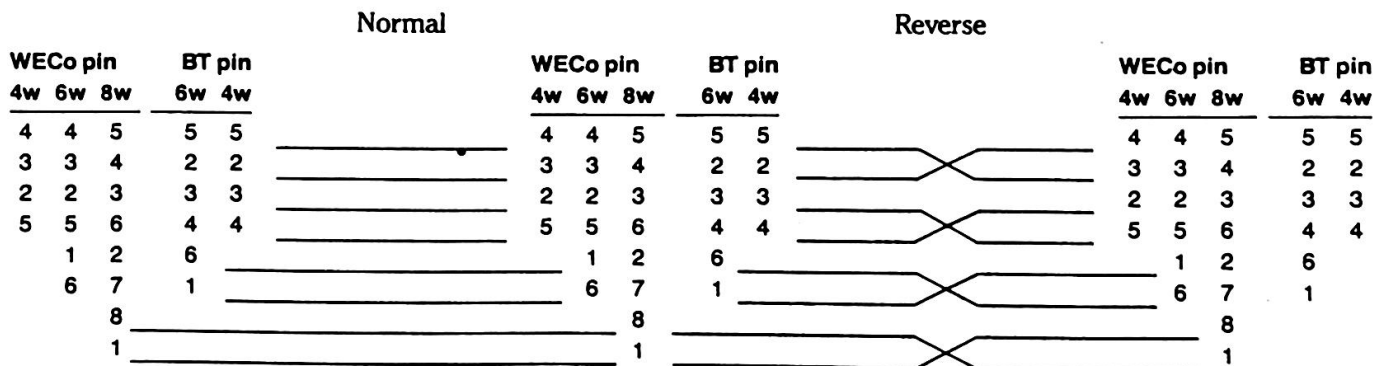

3.08 Sub Distribution

If Sub Distribution is specified a Trunk Cable is run from the MDF to each SDF. Drop Side SDFs are usually located in utility closets.

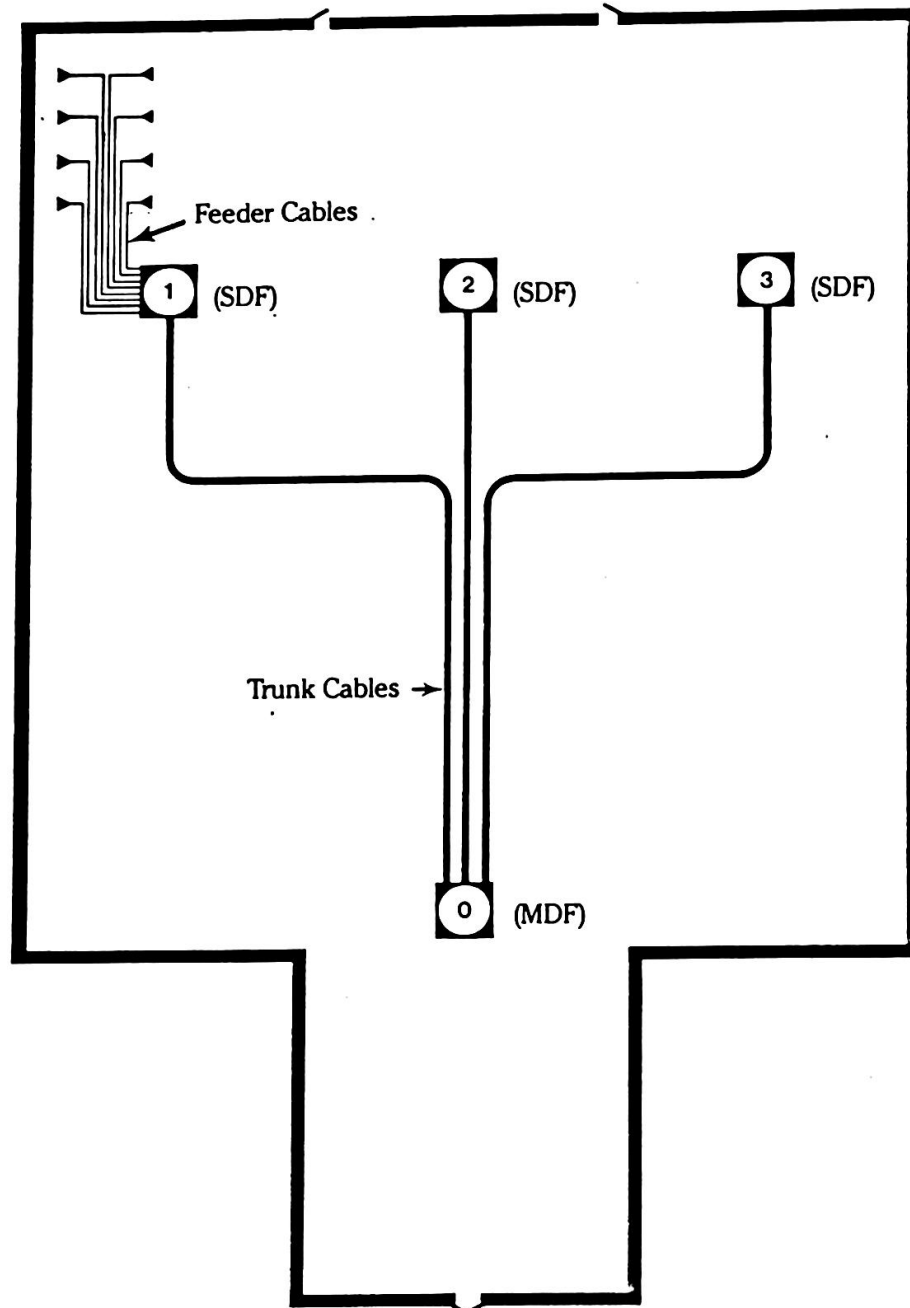

Local Area Network (LAN) 3.09

LAN Node at Distribution Frame

Wiring Grid Feeder Cables and Fixed Drop Runs are terminated on the Distribution Frame, as are the Trunk Cable and cables from the LAN Node for low speed connections.

On the Distribution Frame a Drop would be cross connected to either a Trunk Channel or a LAN Equipment channel.

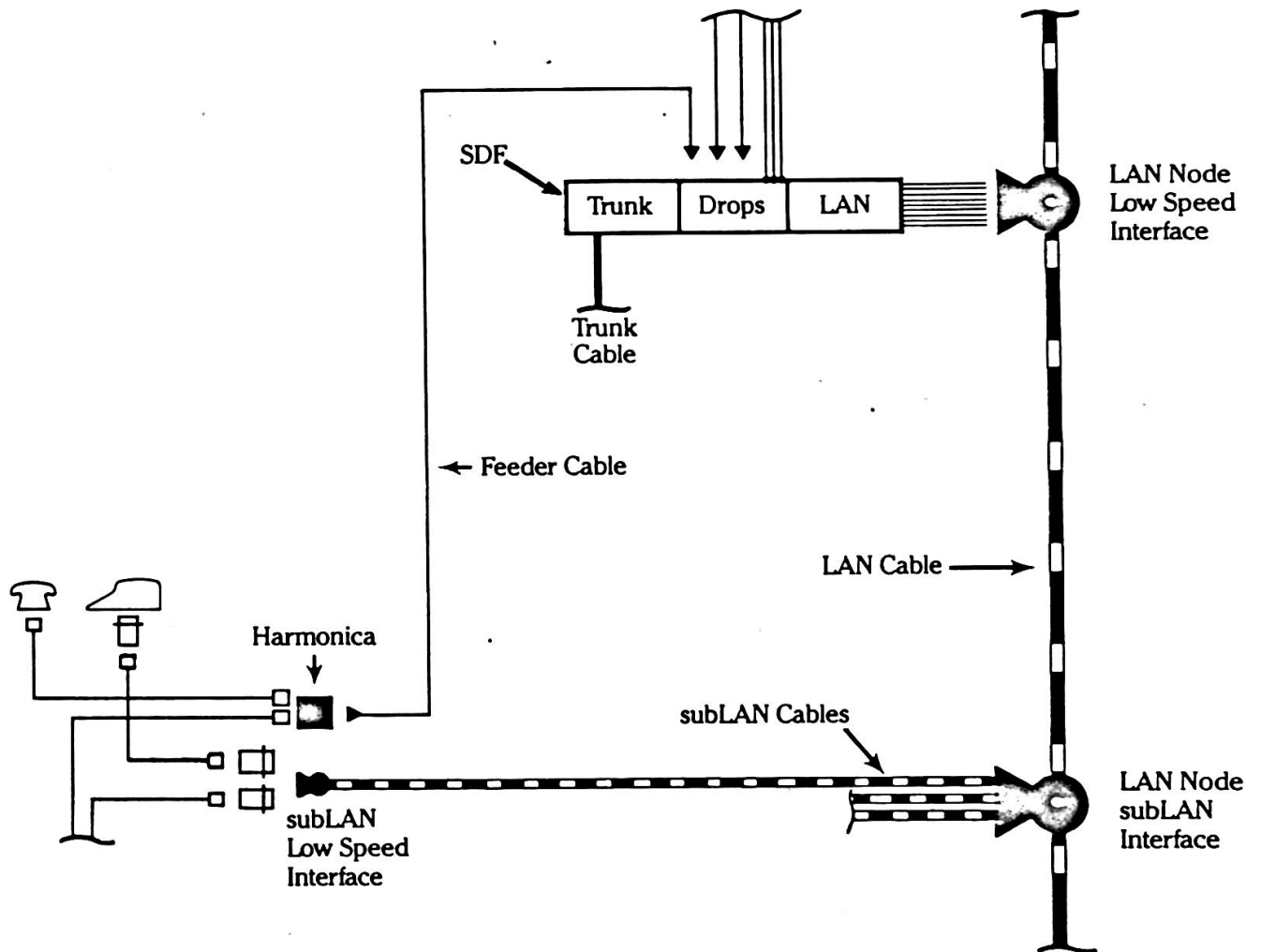

subLAN Node at the Work Station

If a subLAN Node with Low Speed Multiplexing is located at the work station it should be placed adjacent to the Wiring Grid Feeder Cable end with Harmonica. A Drop Run could then be attached to either the Harmonica or the subLAN Node.

3.10 Nomenclature

Distribution Frame ID

DFID = 0 for the MDF
= 1, 2, 3, ...(sequential) for SDFs

Feeder Cable ID

FCID = [DFID, Distribution Frame ID] + [01, 02, 03, ...(sequential)]

Feeder Cable Channel ID

FCCID = [FCID, Feeder Cable ID] +
for 4w Drops: [01, 02, 03, ..., 12]
for 6w Drops: [01, 02, 03, ..., 08]
for 8w Drops: [01, 02, 03, ..., 06]

Demountable Drop ID

DID = [FCCID, Feeder Cable Channel ID]

Fixed Drop Run ID

FXRID = [DFID, Distribution Frame ID] + [01, 02, 03, ...(sequential)]

Fixed Drop ID

DID = [DFID, Distribution Frame ID] + [pseudoFeeder ID, NN] +
for 4w Drops: [01, 02, 03, ..., 12]
for 6w Drops: [01, 02, 03, ..., 08]
for 8w Drops: [01, 02, 03, ..., 06]

NN is sequential yet unique from Feeder Cable ID sequence. Normally NN starts at [Last Feeder Cable Sequential Number + 1.]

Examples

DID = 12302
indicates channel 2 on Feeder 23 run from SDF 1.

DID = 30212
indicates channel 12 on Feeder 2 run from SDF 3.

DID = 00208
indicates channel 8 on Feeder 2 run from MDF.

SCHEDULE 0 COLOR CODE

Normal Wiring Illustrated

WE 4 & 6w Cord



1 2 3 4 5 6

Cndr ID	WE6w pin	Cord Color
T3	1	White
T2	2	Black
R1	3	Red
T1	4	Green
R2	5	Yellow
R3	6	Blue

omit T3 (1) and R3 (6) on 4-wire version.

WE 8w Cord



1 2 3 4 5 6 7 8

Cndr ID	WE8w pin	Cord Color
R4	1	Blue
T3	2	Orange
T2	3	Black
R1	4	Red
T1	5	Green
R2	6	Yellow
R3	7	Brown
T4	8	Slate

BT 4 & 6w Cord



1 2 3 4 5 6

Cndr ID	WE6w pin	Cord Color
T3	1	Orange
R1	2	Red
T2	3	Blue
R2	4	Green
T1	5	White
R3	6	Black

omit T3 (1) and R3 (6) on 4-wire version.

Color Code: Band Stripe

50-position Pair	Pin	25-pair Color	Cndr
1	26	Wht	1T
	1	Blu	1R
2	27	Wht	2T
	2	Org	2R
3	28	Wht	3T
	3	Gm	3R
4	29	Wht	4T
	4	Bm	4R
5	30	Wht	5T
	5	Slt	5R
6	31	Red	6T
	6	Blu	6R
7	32	Red	7T
	7	Org	7R
8	33	Red	8T
	8	Gm	8R
9	34	Red	9T
	9	Bm	9R
10	35	Red	10T
	10	Slt	10R
11	36	Blk	11T
	11	Blu	11R
12	37	Blk	12T
	12	Org	12R
13	38	Blk	13T
	13	Gm	13R
14	39	Blk	14T
	14	Bm	14R
15	40	Blk	15T
	15	Slt	15R
16	41	Yel	16T
	16	Blu	16R
17	42	Yel	17T
	17	Org	17R
18	43	Yel	18T
	18	Gm	18R
19	44	Yel	19T
	19	Bm	19R
20	45	Yel	20T
	20	Slt	20R
21	46	Vlt	21T
	21	Blu	21R
22	47	Vlt	22T
	22	Org	22R
23	48	Vlt	23T
	23	Gm	23R
24	49	Vlt	24T
	24	Bm	24R
25	50	Vlt	25T
	25	Slt	25R

4w Channels

4w Chnl #	Chnl Cndr ID	WECO 4w Color
01	T1	Green
	R1	Red
02	T2	Black
	R2	Yellow
03	T1	Green
	R1	Red
04	T2	Black
	R2	Yellow
05	T1	Green
	R1	Red
06	T2	Black
	R2	Yellow
07	T1	Green
	R1	Red
08	T2	Black
	R2	Yellow
09	T1	Green
	R1	Red
10	T2	Black
	R2	Yellow
11	T1	Green
	R1	Red
12	T2	Black
	R2	Yellow
-	-	-

6w Channels

6w Chnl #	Chnl Cndr ID	WECO 6w Color
01	T1	Green
	R1	Red
	T2	Black
02	R2	Yellow
	T3	Orange
	R3	Brown
03	T1	Green
	R1	Red
	T2	Black
04	R2	Yellow
	T3	Orange
	R3	Brown
05	T1	Green
	R1	Red
	T2	Black
06	R2	Yellow
	T3	Orange
	R3	Brown
07	T1	Green
	R1	Red
	T2	Black
08	R2	Yellow
	T3	Orange
	R3	Brown
09	T1	Green
	R1	Red
	T2	Black
10	R2	Yellow
	T3	Orange
	R3	Brown
11	T1	Green
	R1	Red
	T2	Black
12	R2	Yellow
	T3	Orange
	R3	Brown
-	-	-

8w Channels

8w Chnl #	Chnl Cndr ID	WECO 8w Color
01	T1	Green
	R1	Red
	T2	Black
	R2	Yellow
02	T3	Orange
	R3	Brown
	T4	Slate
	R4	Blue
03	T1	Green
	R1	Red
	T2	Black
	R2	Yellow
04	T3	Orange
	R3	Brown
	T4	Slate
	R4	Blue
05	T1	Green
	R1	Red
	T2	Black
	R2	Yellow
06	T3	Orange
	R3	Brown
	T4	Slate
	R4	Blue
07	T1	Green
	R1	Red
	T2	Black
	R2	Yellow
08	T3	Orange
	R3	Brown
	T4	Slate
	R4	Blue
-	-	-

WE4w



WE6w



WE8w



WE8k



R₄ T₂ R₁ T₁ R₂ R₃ T₄

BT4L



BT4H



BT6L



BT6H



Chnl Cndr ID	WECO 4w Pin	WECO 4w Color
T1	4	Green
R1	3	Red
T2	2	Black
R2	5	Yellow

Chnl Cndr ID	WECO 6w Pin	WECO 6w Color
T1	4	Green
R1	3	Red
T2	2	Black
R2	5	Yellow
T3	1	WHT Orange
R3	6	BLU Brown

Chnl Cndr ID	WECO 8w Pin	WECO 8w Color
T1	5	Green
R1	4	Red
T2	3	Black
R2	6	Yellow
T3	2	WHT Orange
R3	7	BLU Brown
T4	8	Slate
R4	1	Blue

Chnl Cndr ID	BT 4w Pin	BT 4w Color
T1	5	White
R1	2	Red
T2	3	Blue
R2	4	Green

Chnl Cndr ID	BT 6w Pin	BT 6w Color
T1	5	White
R1	2	Red
T2	3	Blue
R2	4	Green
T3	1	Orange
R3	6	Black

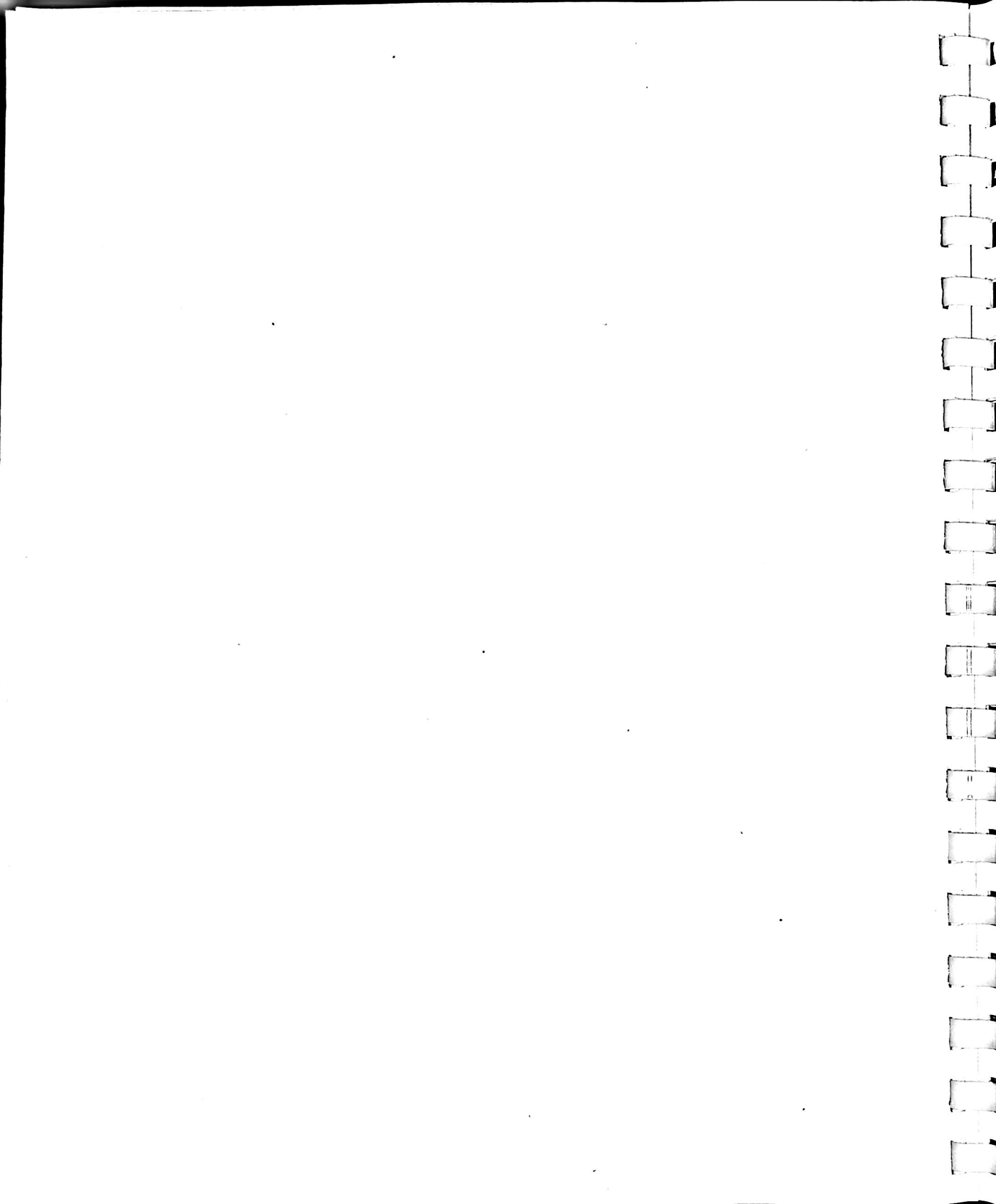

4.02 System Equipment

4.03 Equipment Interface

4.04 System Connects

4.05 Modular Polarisation Combinations

4.05 Standard System Side Polarisations

4.06 Feeder Cables

4.07 Sub Distribution













4.07 Nomenclature



4.02 System Equipment

Systems are any equipment with multiple channels. Connections at Systems are classified by type of equipment and use of channel to facilitate later layout of Distribution Frames.

The classification scheme will depend upon the equipment mix. Illustrated below is a suggested scheme to handle the most common equipment configurations.

Class ID	Data and Voice Configuration	Data over Voice Configuration	Integrated D&V Configuration
1	Misc Voice Analog Side		
2	 Network Interface Customer Side		
3	 Voice Switch NI Side		 Intg'd Sw NI Side
4			 Intg'd Sw I Drop Side
5	 Voice Switch Drop Side		 Intg'd Sw V Drop Side
6		 Data over Voice Voice Side	
7		 Data over Voice Drop Side	
8		 Data over Voice Data Side	
9	 Data Switch Drop Side		
10	 Data Switch System Side		
11	 Computer Systems		
12			 Intg'd Sw System Side
13	Misc Data Digital Side		

Equipment Interface 4.03

Number of Wires per Channel

Standard is to allow 6 wires per channel for all System equipment. 4-wire and 8-wire channels are also available.

Typical Voice Allocation

T1 Tip
R1 Ring
T2 as req'd
R2 as req'd
T3 as req'd
R3 as req'd

Typical Data Allocation*

T1 DataIn
R1 OtherEndRdy
T2 DataOut
R2 Ground
T3 Ready
R3 RingIndic

(*sequence shown is for RS-232 DTE Computer System)

Number of Channels

It is good practice to specify the actual current number of channels as well as an allowed number of channels which the equipment will eventually support.

Mechanical Interface

Specify the type of termination provided on the equipment (connector style, sex) for cable attachment. A System Connect will adapt the equipment termination to the Wiring Grid standard connector.

Electrical Interface

Specify the pin assignment of signals for each type of termination provided on the equipment. The System Connect will adapt the equipment's sequence of signals to the Wiring Grid standard sequence.

4.04 System Connects

System Connects adapt the equipment interface to the Wiring Grid Feeder Cable.

Feeder Extension

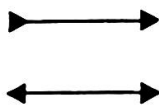

Used to extend or change the sex of a Feeder Cable. Feeder Extensions are factory wired with 50position plugs and connectors as specified.

Octopus Direct

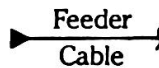

Attaches a Feeder Cable 50posn to equipment with modular jacks.

Octopus with Interface Adapters

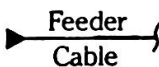

Attaches a Feeder Cable 50position to equipment with D-type connectors.

Harmonica with Line Cords

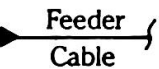
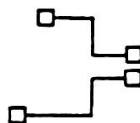

Attaches a Feeder Cable 50position to single channel equipment with a modular jack.

Harmonica with Line Cords and Interface Adapters

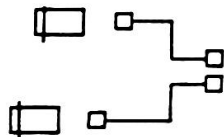

Attaches a Feeder Cable 50position to single channel equipment with D-type.

Cross Wye



Attaches a Feeder Cable 50position to equipment with 50position, or other, multiple-channel Mass Terminate connections.

Modular Polarisation Combinations 4.05









Universal

Modular polarisation for System channels is the same for all equipment.

Dedicated

A Voice polarisation is used for Voice channels. A different Data polarisation is used for Data channels.

Standard System Side Polarisations

		4w chnls	6w chnls	8w chnls
Universal	Voice			
	Data	WEC04w	WEC06w	WEC08w
Dedicated	Voice			
	Data			
		BT4wH	BT6wH	

4.06 Feeder Cables

25pair Inside Wire Cable (IWC) run from Equipment location to Distribution Frame. Equipment end is field wired with a female 50position connector. Distribution Frame end is field wired with a 50position male plug.

Feeder Extensions

Used to extend or change the sex of Feeder Cables. Feeder Extensions are factory wired with 50position plugs/connectors at each end.

Routing

Preferred routing in System Rooms is overhead in cable tray hung below the finish ceiling. Use PVC insulated and jacketed IWC cable.

Alternately, Feeder Cables may be routed underfloor if a raised access floor is provided. If the underfloor plenum is forced air FRD insulated and jacketed IWC cable may be required.

Number of Runs

For 4w channels divide the number of equipment channels by 12 and round up to next whole number. For 6w channels divide by 8, for 8w channels divide by 6.

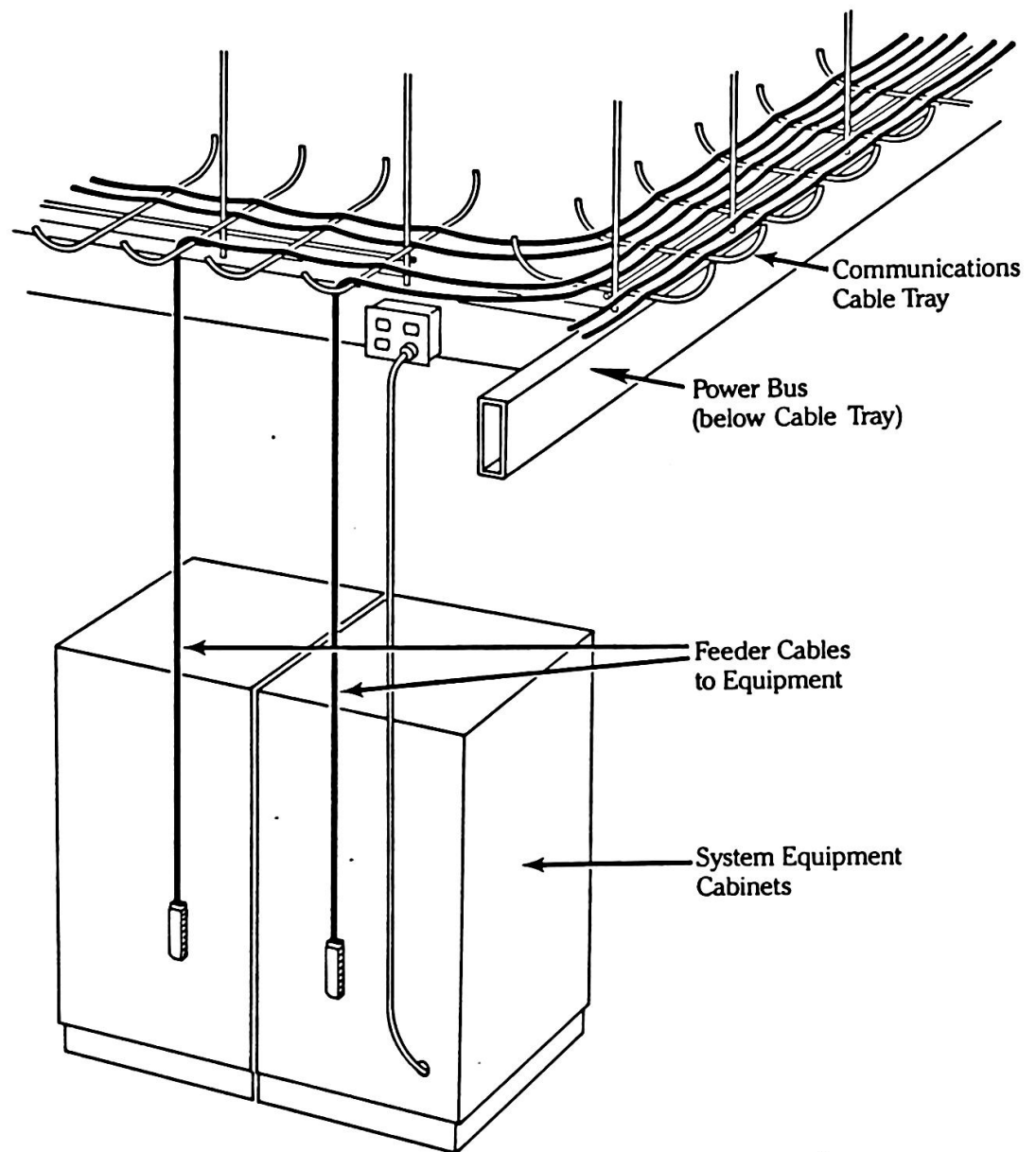

If Sub Distribution is specified a Trunk Cable is run from the MDF to each SDF. System Side SDFs are usually located in System Rooms distant from the MDF.

Nomenclature

Distribution Frame ID

DFID = 0 for the MDF
= 1, 2, 3, ...(sequential) for SDFs

Feeder Cable ID

FCID = [DFID, Distribution Frame ID] + [CID, System Equipment Class ID]
+[01, 02, 03, ...(sequential)]

Feeder Cable Channel ID

FCCID = [FCID, Feeder Cable ID] +
for 4w channels: [01, 02, 03, ..., 12]
for 6w channels: [01, 02, 03, ..., 08]
for 8w channels: [01, 02, 03, ..., 06]

System Equipment Channel ID

SID = [FCCID, Feeder Cable Channel ID]

System Equipment Class ID

CID = (as defined)

Examples

SID = 010-0708
indicates channel 8 on Feeder 7 run to Equipment Class 10 (Data Switch, System Side) from the MDF.

SID = 109-1201
indicates channel 1 on Feeder 12 run to Equipment Class 9 (Data Switch, Drop Side) from SDF 1.

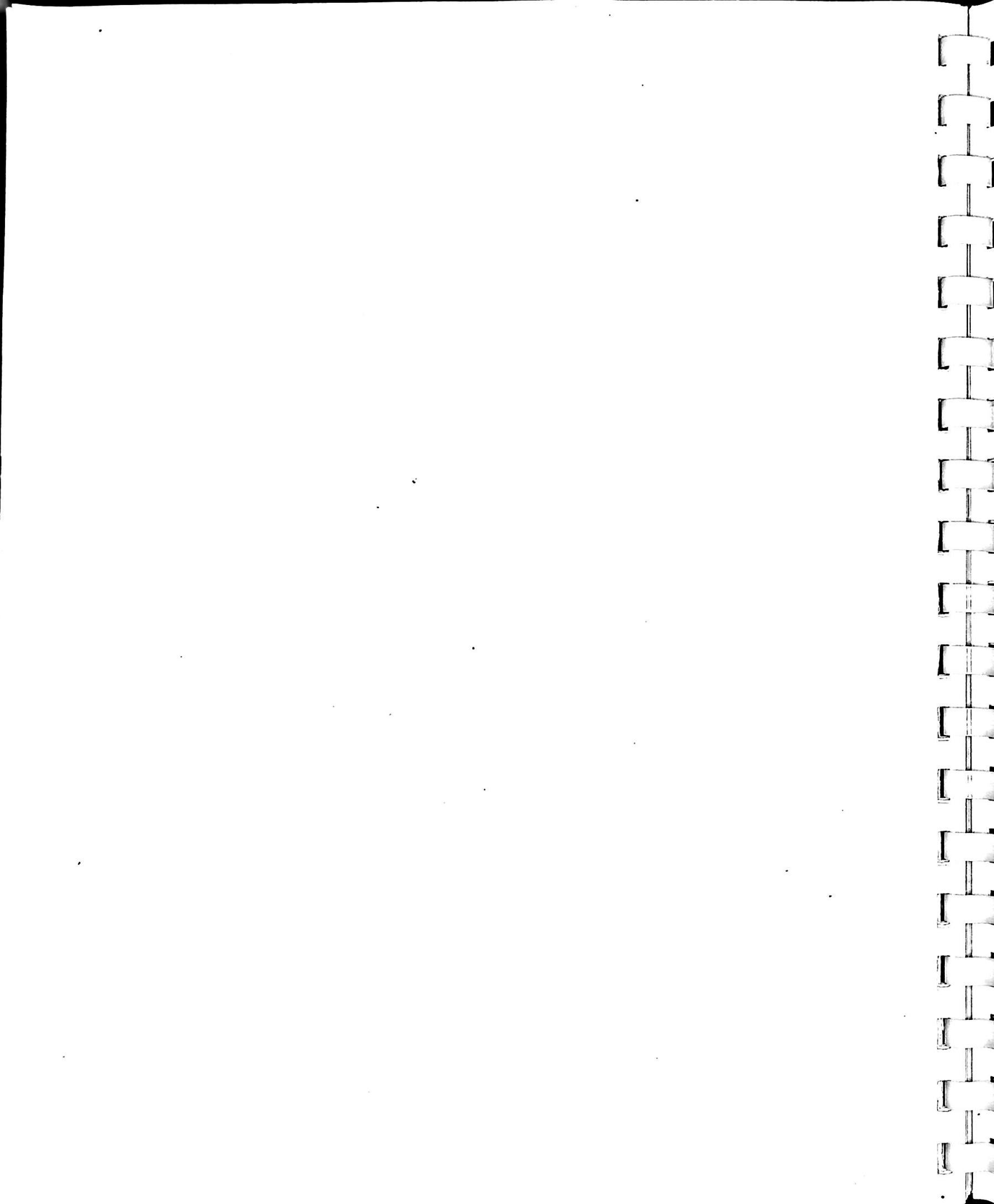

5.02 Distribution Frames

5.02 Terminations

5.03 Logical Sections

5.04 Rack Mount Frame

5.05 Open Bay Rack

5.05 Rack Accessories

5.06 Rack Mount 66M Blocks

5.07 Rack Mount Modular Patching

5.08 Modular Polarisation Considerations

5.08 Standard Modular Patching Polarisations

5.09 Trunk Cables

5.10 Sub Distribution without a Local Area Network

5.11 Sub Distribution with a Local Area Network

5.12 Wall Mount 66M Blocks

5.13 Wall Mount BICX System

5.14 Nomenclature

5.15 Cross Connects



5.02 Distribution Frames

Wiring Grid cable channels are interconnected at Distribution Frames.

Main Distribution Frame (MDF)

Central cross connect point usually located near the largest concentration of channels.

Sub Distribution Frames (SDFs)

Intermediate cross connect points usually located in utility closets (Drop Side) or System Rooms (System Side). A Trunk Cable is run from each SDF to the MDF.

Terminations

Connectorized Termination

Used to terminate connectorized Drop Side and System Side Feeder Cables at a Distribution Frame. The Feeder's male 50position plugs into the Frame's female connector.

Cutdown Termination

Used to terminate Trunk Cables, Fixed Drop Runs, and unconnectorized Feeder Cables at a Distribution Frame. Each cable conductor is field terminated (cutdown) on the Frame.

Splice Termination

Used to splice a Trunk Cable to connectorized Feeder Cables at a Distribution Frame. The Trunk Cable is cutdown, the Feeder Cable is connectorized. Any channel's splice may be opened at any time for other-than-splice cross connections.

Logical Sections 5.03

In order to facilitate cross connections on the Distribution Frame cables should be terminated in an orderly manner.

Illustrated below are Distribution Frame Logical Layouts for the System Equipment classifications defined previously. Standard cross connections are indicated as lines between Logical Sections. Misc Voice and Misc Data are cross connected as required. Note that some equipment is terminated in more than one Logical Section.

Data and Voice

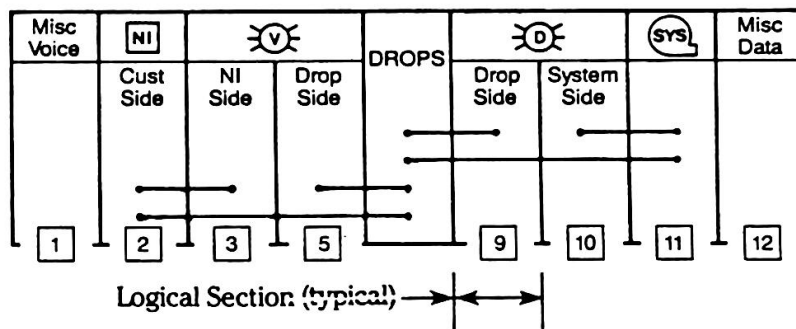

Data Over Voice

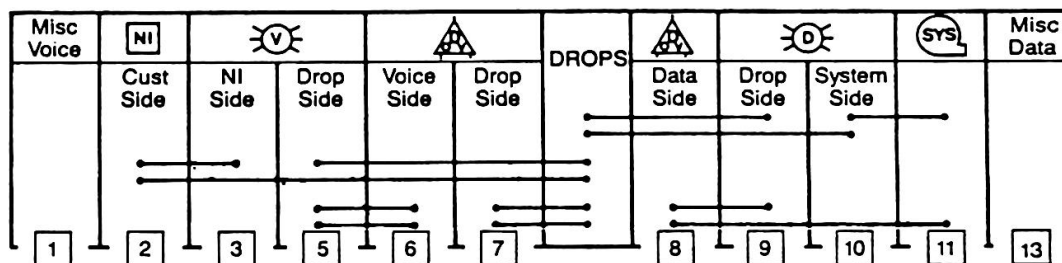

Integrated Data Voice

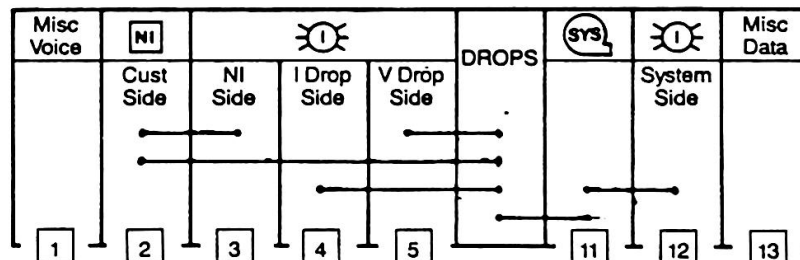

5.04 Rack Mount Frame

A Rack Mount Frame consists of several Open Bay Racks bolted together and fastened at the top to an adjacent wall and at the bottom to the floor.

Each Bay provides 43 EIA-standard 19 inch wide by 1 $\frac{3}{4}$ inch high mounting positions.

The top mounting position is reserved for a blank panel with nomenclature. The balance of the bay is divided into three 14-position sections: top, middle, and bottom.

66M Blocks and Modular Patching may be used to provide connectorized, cutdown, and splice terminations.

It is good practice to leave the bottom section spare for future use. Whenever possible allow space at both ends of frame for future addition of bays.

The Open Bay Rack may also be used to mount 19 inch wide equipment.

Number of Open Bay Racks	1	5	10	15	20	25
Minimum W, in feet, approx.	2	9	17	26	34	43

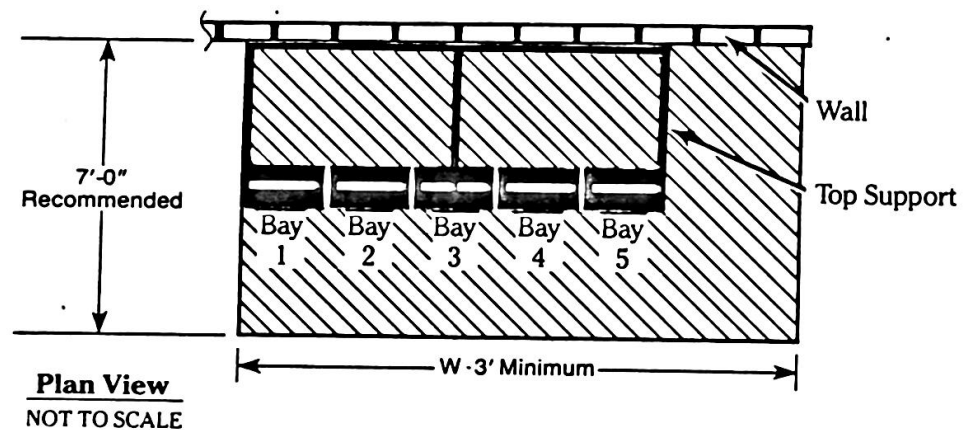

Open Bay Rack 5.05

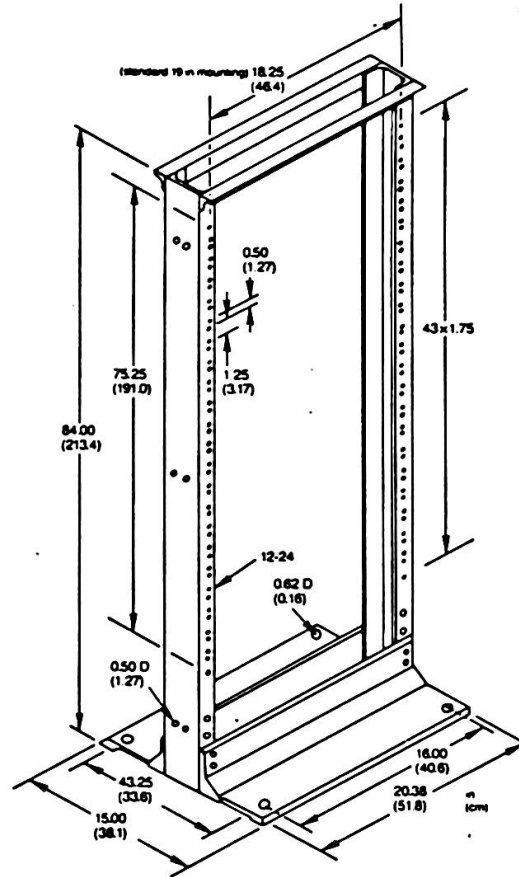

Open Bay Rack 43 positions

Rack Accessories

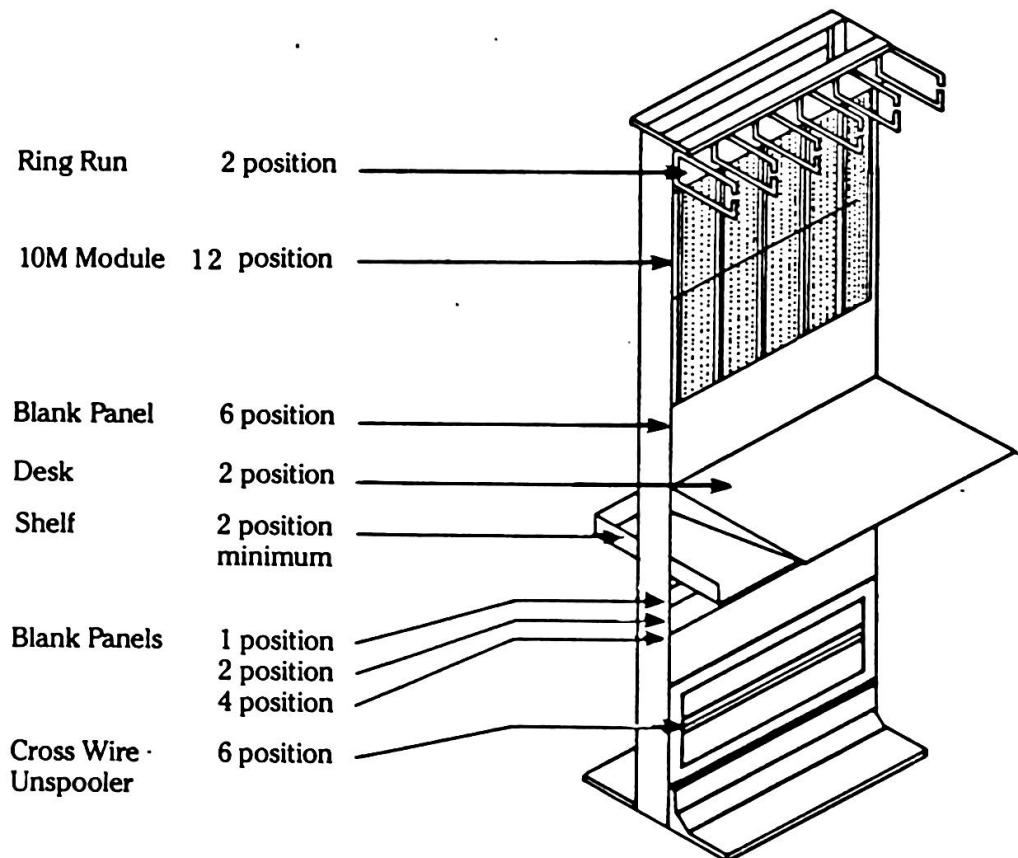

5.06 Rack Mount 66M Blocks

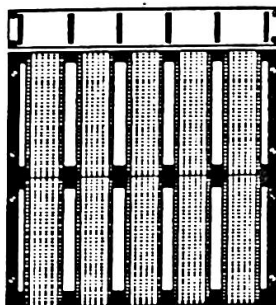

Up to 10 66M Blocks may be mounted in each 14 position Frame section. 1 Ring Run and 1 10M Module required per Section.

Cross wire is used to cross connect channels between blocks.

Bridging Clips are used to splice horizontally adjacent channels on the same block.

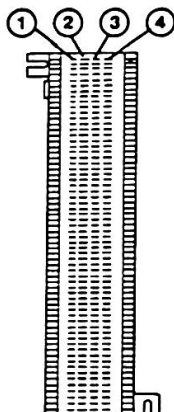

66M Blocks are 4 clips wide by 50 clips high. Wired blocks have a specified number of 50 position female connectors mounted on the rear of the block bracket and wired to wire wrap tails on the 66M clips.

Unwired 50UW Block

Block for 50 pairs of cutdown terminations. Internal bridging of column 1 to 2 and column 3 to 4. Cable conductors terminated on columns 1 and 4. Cross Wire installed on columns 2 and 3.

Wired 50C2 Block

Block with two 50 position connectors. Terminates 2 25pair connectorized Feeders or 50pairs of cutdowns. Internal bridging of column 1 to 2 to connector 1 and column 3 to 4 to connector 2.

Wired 100C2 Block and Bridging Clips

Block with two 50 position connectors used to splice 2 25pair connectorized Feeders to 50pairs of cutdowns. The two connectors are factory wired to columns 2 and 3. Cutdown terminations are made on columns 1 and 4. Bridging clips may be used across columns 1 and 2 and across 3 and 4 to splice channels. Without bridging clips Feeder channel and Trunk channel may be cross connected with cross wire.

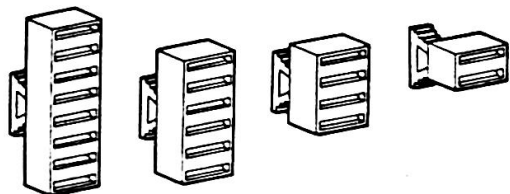

Wired 100C4 Block

Block with four 50 position connectors. Terminates 4 25pair connectorized Feeders. Connector 1 wired to column 1, connector 2 to column 2, 3 to 3, and 4 to 4.

Rack Mount Modular Patching 5.07

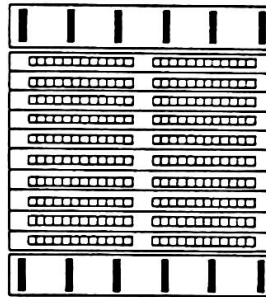

Up to 10 Modular Patching or MOD-FIT Panels may be mounted on each 14 position Frame section. 2 Ring Runs required per Modular Patching (MP) Section.

Modular patch cords are used to cross connect channels.

Modular Patching Panels provide 24 modular jacks on the front face factory wired to female 50position connectors on the back. They terminate connectorized Feeder Cables.

MP4W Panel with 4-wire channels



2 groups of 12 modular jacks wired to 2 50position connectors.

MP6W Panel with 6-wire channels



3 groups of 8 modular jacks wired to 3 50position connectors.

MP8W Panel with 8-wire channels



2 groups of 12 modular jacks wired to 4 50position connectors.

MOD-FIT Panels mount MOD-FIT modular jacks. Cable conductors are cutdown on each jack. Use for terminating Trunk Cable and Fixed Drop Run channels.

MF12 Panel with 12 MOD-FIT Jacks

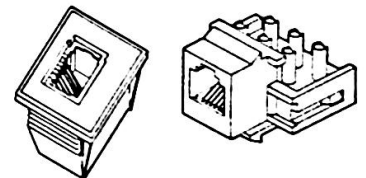









5.08 Modular Polarisation Considerations

If the Drop Side is wired with Dedicated Drops and Harmonicas and the System Side is also wired with Dedicated polarisations then Modular Patching may be specified Dedicated.

In all other cases Modular Patching should be specified with Universal polarisation.

Standard Modular Patching Polarisations

		4w chnls	6w chnls	8w chnls
Universal	Voice			
	Data	WECO4w	WECO6w	WECO8w
Dedicated	Voice			
	Data			

Trunk Cables 5.09

If Sub Distribution is specified Trunk Cables are run from the MDF to each SDF.

Trunk Cable is typically multiple runs of 100pair IWC cable or 600 or 1200pair Aerial/Duct (A/D) cable. It is PVC insulated and jacketed. Preferred routing is within 4inch EMT, or equiv, raceway.

Where the Trunk serves a Drop Side SDF it is terminated in the Drops section of the MDF. Where the Trunk serves a System Side SDF it is terminated in the logical sections assigned to the equipment on the MDF.

25pair Groups

Conductors are arranged in groups of 25pairs each. 24 groups comprise a Super Group. Groups and Super Groups are identified by nylon tracers running the length of the Trunk Cable.

Super Group	25pair Group	Cable Pairs	
1	1	1-25	
	2	26-50	
	3	51-75	
	4	76-100	
	5-8	101-200	
	9-12	201-300	
	13-16	301-400	
	17-20	401-500	
	21-24	501-600	
	2	25	601-625
		26	626-650
		27	651-675
28		676-700	
29-32		701-800	
33-36		801-900	
37-40		901-1000	
41-44		1001-1100	
45-48	1101-1200		

5.10 Sub Distribution without a Local Area Network

To avoid unnecessary cross connects size the Trunk Cable so that it can handle all Feeder Cable and Fixed Drop Run channels cabled to the SDF (with allowance for future growth, if required).

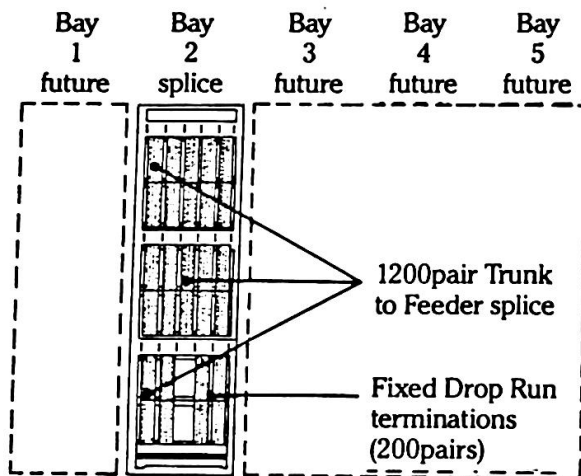

In the configuration shown Bay 2 is provided with 24 100C2 66M Blocks to splice up to 48 connectorized Feeders to 1200 cutdown Trunk pairs. Four 50UW 66M Blocks are provided to terminate up to 200 pairs of Fixed Drop Run cutdowns.

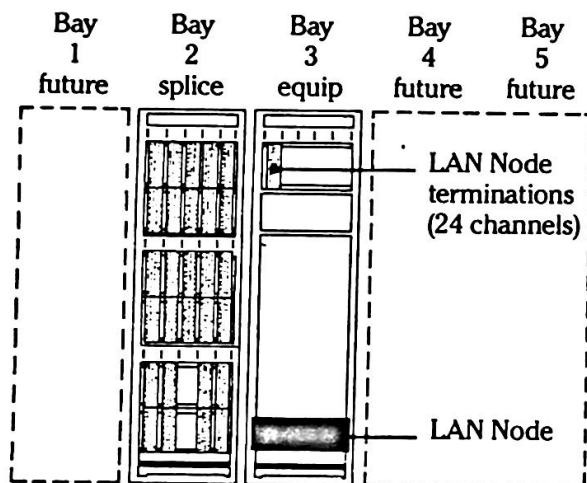

If a Local Area Network is later added a Node with Low Speed Multiplexing can be mounted, along with its low speed cable terminations, in Bay 3.

To cross connect a Feeder Cable channel into the LAN lift the appropriate Bridging Clip on the 100C2 Block and install a cross wire from the Feeder Cable clips to the Equipment clips.

Sub Distribution with a Local Area Network 5.11

If more than just a few Drops are to be cross connected into the Local Area Network at the Frame allow three logical sections: Trunk, Drops, and Equipment.

Each Drop channel may be cross wired to either a Trunk Cable channel or a LAN equipment channel.

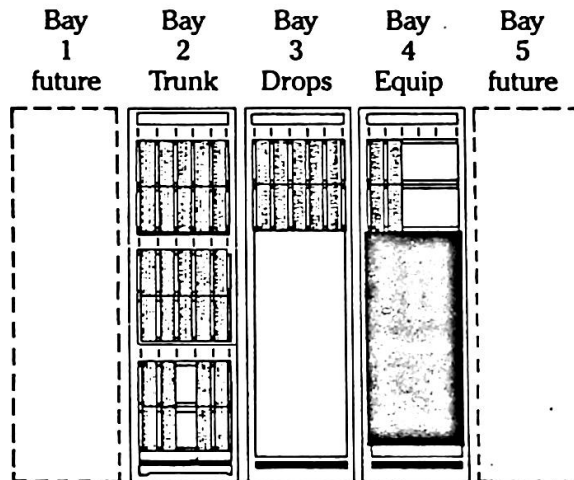

5.12 Wall Mount 66M Blocks

Used as an alternate for cutdown terminations.

8M Panels mount up to 8 50UW 66M Blocks each. 16P Panels provide routing for cross wiring. Both are mounted on plywood on a wall.

Allow space at top and bottom for cable routing. The bottom section is normally reserved for future expansion. Wherever possible allow space at both ends of Frame for future use.

Number of Verticals:	1	5	10	15	20	25
Minimum W, in feet (approx):	2	8	15	22	29	36

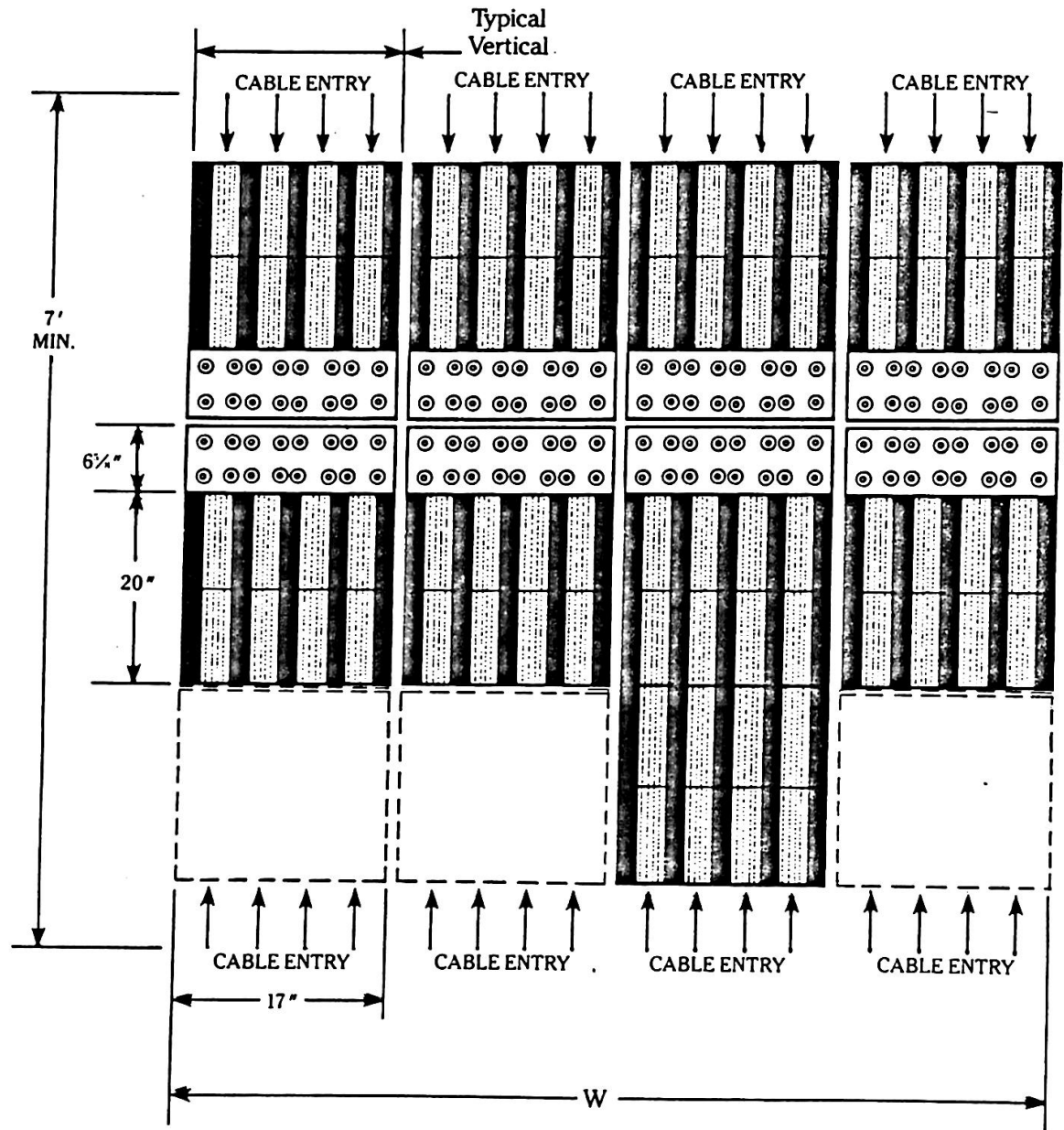

Wall Mount BICX System 5.13

Used as an alternate for cutdown terminations.

Brackets mount up to 10 Connectors each. Connectors each terminate 25pairs. Rings are used to provide routing for cross wiring and cables. Rings and Brackets are mounted on plywood on a wall.

Allow space at both ends of Frame wherever possible for future use.

Number of Verticals:	1	5	10	15	20	25
Minimum W, in feet (approx):	3	10	19	28	37	46

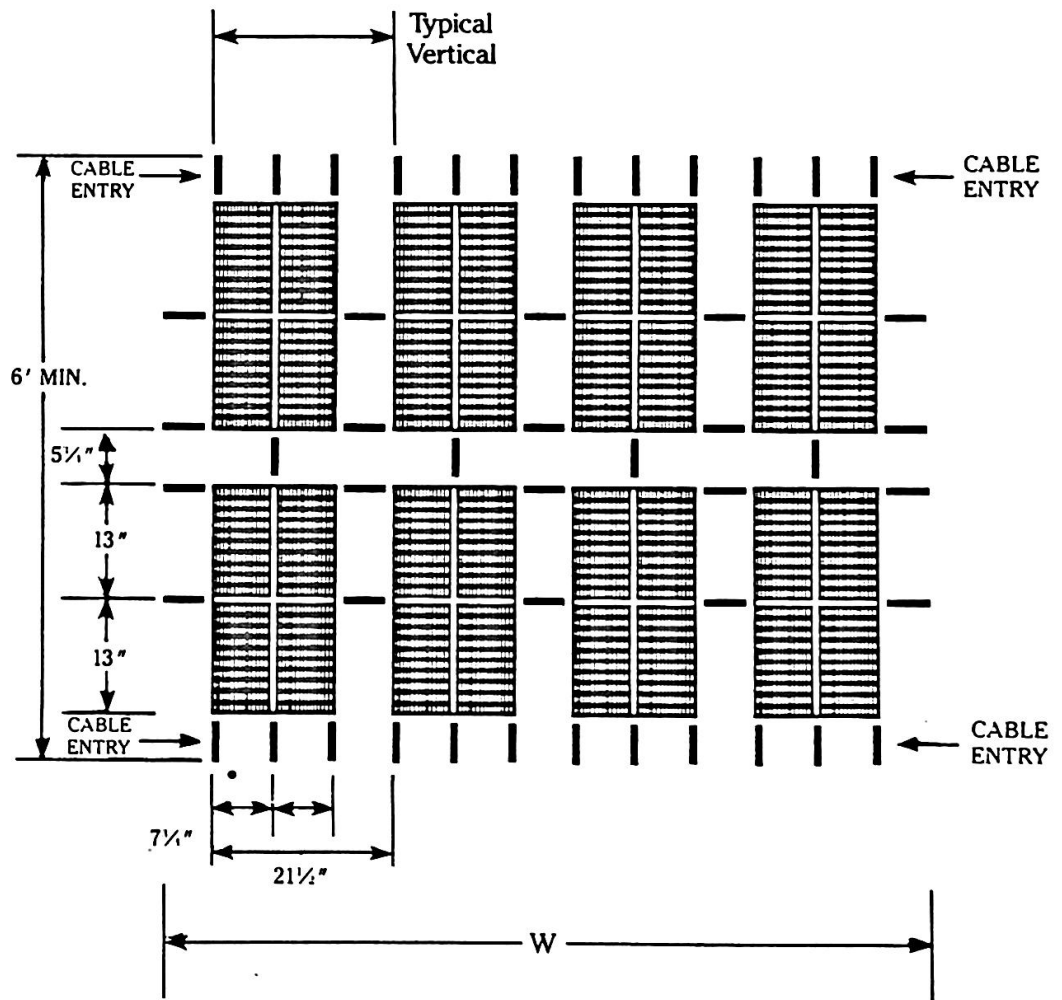

5.14 Nomenclature

Distribution Frame ID

DFID = 0 for the MDF
= 1, 2, 3, ... (sequential) for SDFs

Distribution Frame Logical Section ID

DFLSID = [CID, System Equipment Class ID] for System Side cables
or
= [DROPS] for Drop Side Cables

Trunk Cable ID

TCID = [DFID, Distribution Frame ID]

Trunk Cable Channel ID

TCCID = [TCID, Trunk Cable ID] + [25pair Group ID] +
for 4w channels: [01, 02, 03, ..., 12]
for 6w channels: [01, 02, 03, ..., 08]
for 8w channels: [01, 02, 03, ..., 06]

Examples

TCCID = 7-1201
indicates channel 1 on 25-pair group 12 of the Trunk Cable run from the MDF to SDF 7.

TCCID = 1-0911
indicates channel 11 on 25-pair group 9 of the Trunk Cable run from the MDF to SDF 1.

Terminations at Distribution Frames should be adequately labeled to enable quick location of any Wiring Grid channel.

No Sub Distribution

Bookkeeping is simplified because all cross connects are made at the MDF.

With Sub Distribution

In addition to cross connects made at the MDF, those made at SDFs also need to be tracked.

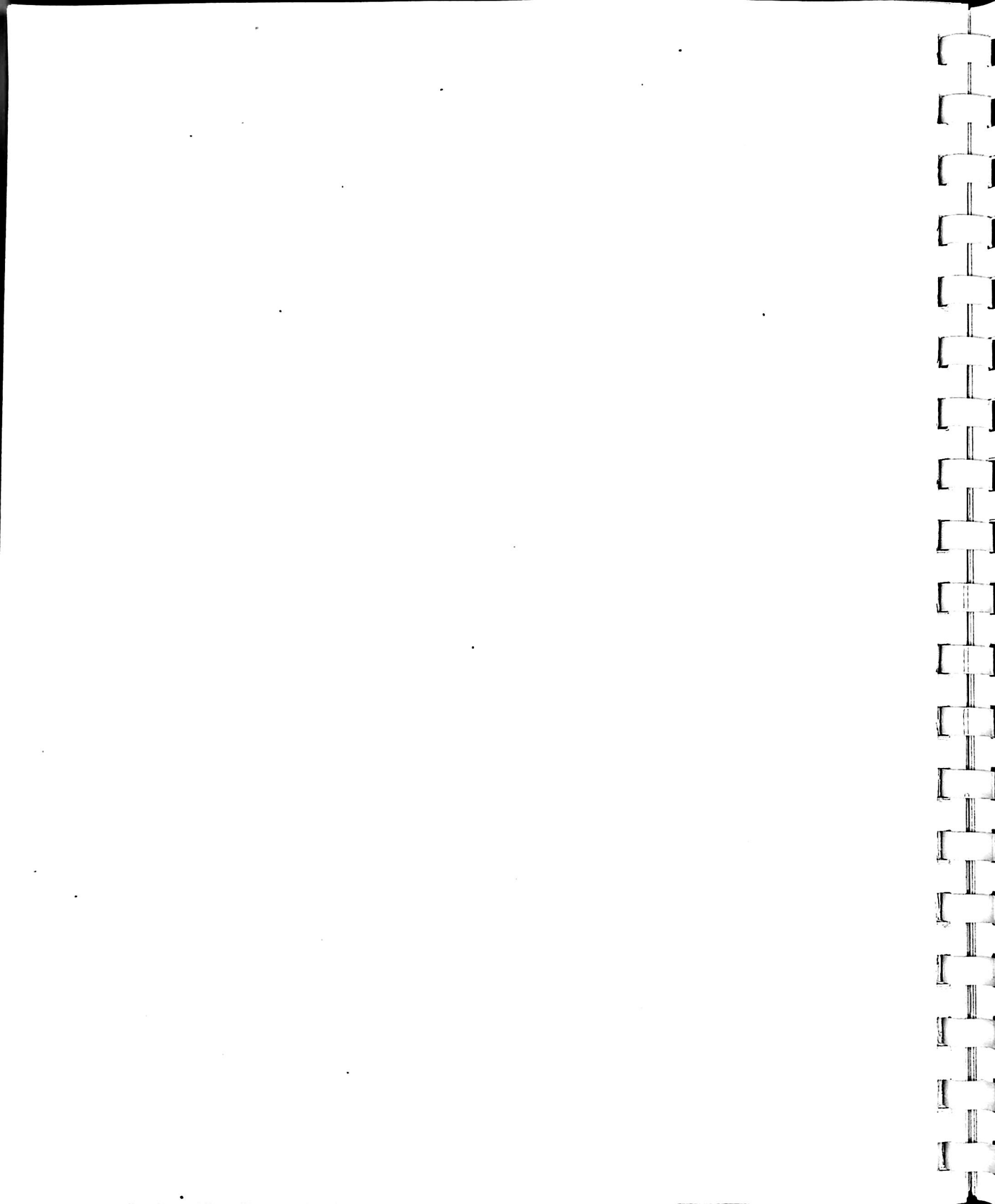

6.02 Consumables

6.02 Test Gear

6.03 Tools

6.03 Work by Others

6.04 Local Area Network



6.02 Consumables

Allow for installation consumables.

Cable Ties (small, medium, large)

Cable Tags

Cable Marker Cards

Fine Point Marker (Distribution Frame labeling)

Medium Point Marker (all other labeling)

Miscellaneous hardware

Test Gear

Allow for wiring system troubleshooting aids.

Equipment to test for the absence of shorts, opens, and miswires in cabling and apparatus.

Interface Testers for on-line troubleshooting of equipment cross connects.

Adapters and extension cords to simplify the use of the above.

Allow for any required tooling.

Mass terminate field tooling for wiring 50 position plugs and connectors. Use only the tool recommended by the plug/connector manufacturer.

Modular plug crimp tool(s) for modular polarisations specified.

Tooling required to terminate cable conductors on Fixed Drop Plates.

Tooling required for terminating cables and cross connecting channels on Distribution Frames.

Hand Tools (Electrician's belt plus telephone Installation and Repair kit).

Work by Others

Allow for work by other trades.

Core Drilling

Raceway Installation

Cut and Patch

Power Poles

etc.

6.04 Local Area Network

Allow cable, connectors, tooling, and test equipment to install the Local Area Network according to manufacturer's recommendations.



7.02

- Feeder Cables**
- 1.1 Feeder Cable 25pair IWC cable runs shall be inside wire cable with 25 pairs of #24AWG solid Cu conductors, band-stripe color coded.
 - 1.2 PVC insulated and jacketed cable shall meet or exceed REA specification PE-71. It shall be approved for installation in raceway, in exposed locations, and in open air plenums.
 - 1.3 FRD insulated and jacketed cable shall be UL listed as low smoke/low flame cables, DuPont Teflon®, or equivalent. It shall be approved for used in complying with Article 800-3(d) of the National Electrical Code.
 - 1.4 Feeder cable ends shall be wired with 50position plugs and connectors, sex as specified, per Schedule 0 Color Code.
- Feeder Extensions**
2. Feeder Extension shall be a wired assembly of PVC insulated and jacketed 25pair IWC cable and 50position plugs and connectors, sex and length as specified, wired per Schedule 0.
- Octopuses**
3. Octopus shall be a wired assembly of modular cord, modular plugs, and 50position plug. Leg length and modular polarisation as specified, wired per Schedule 0.
- Harmonica**
- 4.1 Harmonica shall be a wired enclosed assembly of modular jacks and 50position plug. Modular polarisation as specified, wired per Schedule 0.
 - 4.2 Harmonica Cover, if specified, shall be an easy to mount enclosure for any Harmonica.
- Demountable Drops**
- 5.1 Demountable Drop shall be a wired modular-to-modular enclosed assembly. Modular polarisations and wiring as specified.
 - 5.2 Demountable Drop Run shall be modular cord with modular plug installed at each end, wired per Schedule 0. Number of wires and style of cord and polarisation of plugs as specified.
 - 5.3 Modular cord shall be PVC insulated and jacketed flat gray cable with the specified number of #26AWG stranded conductors color coded per Schedule 0. Western Electric (WECO) style.
- Fixed Drops**
- 6.1 Fixed Drop shall be a two or four channel, as specified, wall plate for installation on a 1gang surface or recess mounting. Plate shall have the required number of modular jacks, polarisations as specified. Means of attaching #24AWG solid Cu conductors to the jack pins shall be provided.
 - 6.2 Fixed Drop Run shall be IWC inside wire cable with 6 or 12 pairs, as specified, of #24AWG solid Cu conductors, band-stripe color coded per Schedule 0.
 - 6.3 PVC insulated and jacketed, see (1.2) above.
 - 6.4 FRD insulated and jacketed, see (1.3) above.
- Line Cords**
7. Line Cord shall be a wired assembly of modular cord with modular plug at each end, length and modular polarisation as specified, wired Normal (pin-to-pin) unless otherwise noted.
- Interface Adapters**
8. Interface Adapter shall be a wired assembly as specified.
- Trunk Cable**
- 9.1 Trunk Cable is required only if Sub Distribution is specified.
 - 9.2 Trunk Cable 100pair IWC cable runs shall be inside wire cable, PVC insulated and jacketed, with four groups of 25 pairs each. Conductors shall be #24AWG solid Cu with band-stripe color coding.
 - 9.3 Trunk Cable A/D cable runs shall be aerial duct cable, PVC, or equivalent, insulated and jacketed, number of pairs as specified. Conductors shall be #24AWG solid Cu with band-stripe color coding preferred, tracer-mate color coding acceptable. Pairs shall be arranged and identified in groups of 25pair and super groups of 600pair.
- Open Bay Rack**
10. Open Bay Rack shall provide 43 EIA-standard 19 inch wide by 1¾ inch high mounting positions. Each position to have four tapped 12-24 mounting holes. Accessories such as Guard Rail, Ring Run, Desk, Shelf, and Blank Panels shall be provided as specified.

Rack Mount 66M Blocks

- 11.1 10M Module shall mount in an EIA-standard 19 inch wide rack. Height of module not to exceed 21 inches with Ring Run. Module shall have tapped 12-24 mounting holes at 20 locations for mounting 10 66M Blocks.
- 11.2 50UW Block shall be WECO 66M1-50 with mounting bracket and snap-on dust cover.
- 11.3 50C2 Block shall have left side columns 1 and 2 internally bridged and wired to a 50position connector labeled "1". Right side columns 3 and 4 shall be similarly bridged and wired to a 50position connector labeled "2". Connectors shall be mounted on the rear of the block bracket and provided with Velcro retainers, Simon UHB, or equivalent. Snap-on dust cover as (11.2) above.
- 11.4 100C4 Block same as (11.3) except columns 1 and 2 and columns 3 and 4 are not bridged. Each column is wired to a 50position connector, labeling: "1", "2", "3", and "4".
- 11.5 100C2 Block same as (11.3) except columns 1 and 2 and columns 3 and 4 are not bridged. Only columns 2 and 3 are wired to 50position connectors, labeling: "2" and "3".

Cross Wire

12. Cross wire shall be #24AWG paired, unjacketed, PVC insulated and band-stripe color coded, 1-, 2-, or 3-pair as specified.

Bridging Clips

13. Bridging Clips shall externally bridge horizontally adjacent 66M Block clips. Number of vertical rows, 1, 2, 4, 6, or 8, per assembly as specified.

Modular Patching Panels

14. Modular Patching (MP) Panel shall be wired enclosed assembly of modular jacks and 50position connectors. Modular polarisation as specified, wired per Schedule 0. The assembly shall mount in an EIA-standard 19 inch wide rack. The assembly shall provide the equivalent of 24 modular jacks, arranged in a logical manner, per 1¾ inch high mounting position.

MOD-FIT Panels

15. MOD-FIT (MF) Panel shall be an assembly of modular jacks and a mounting panel. The mounting panel shall mount in an EIA-standard 19 inch wide rack. Modular jacks, polarisation as specified, shall provide insulation displacement, or equivalent terminations for #24AWG solid Cu conductors. The assembly shall provide the equivalent of 12 modular jacks, arranged in a logical manner, per 1¾ inch high mounting position.

Modular Patch Cords

16. Modular Patch Cord components shall be provided for the modular polarisation(s) specified. Components to include modular plugs, modular cord, and modular plug crimp tool.

**Wall Mount BICX System
(or equivalent)**

17. Bracket shall be BIX-10A. Connector shall be BIX-1A with BIX-1200 Designation Strip and BIX-1207 Label. Distribution Ring shall be BIX-19A. BIX® is a trademark of Northern Telecom Limited.

Wall Mount 66M Blocks

18. 8M Panel and 16P Panel shall be WECO 180-series, or equivalent. 50UW Block as (11.2) above.

The System in Action

Provides Organization of Communications Wiring

Use of multiple conductor (25 pair) cable from the computer to terminal locations can provide substantial cost savings as well as simplifying the system. Here the terminal area is serviced using Coupling plates and MOD-MOD Adapters or Couplings connected to a Harmonica with line cords.

Computer with MOD Dtype Adapters and Octopus Installed

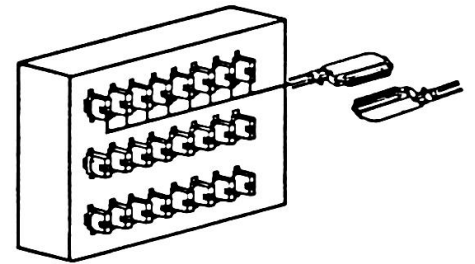

Simplifies Data Switch Cabling

Modular Patching provides simple system reconfiguration for testing, troubleshooting, or changing requirements. Data switch hook-up is accomplished through the use of Cross-Wyes; pre-assembled, pre-tested wiring harnesses. End-to-end connectivity is easily confirmed using MOD-TEST equipment.

Computer

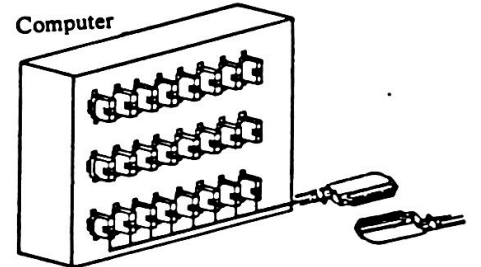

Data Switch

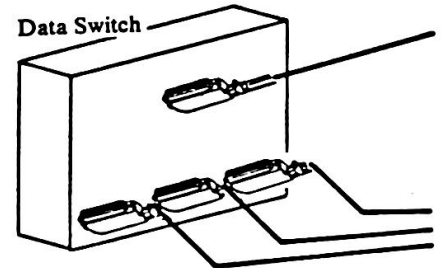

Handles Voice and Data

In the universal system shown, voice and data channels are combined into a common 25 pair feeder cable to the Drop section of a distribution frame. Cross connect wiring then defines each channel as voice or data. The option of individual runs to fixed office locations is accomplished using MOD-Barrel Plates.

Voice Switch

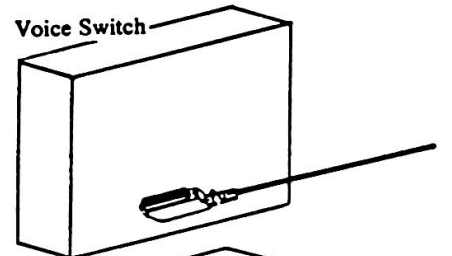

Computer

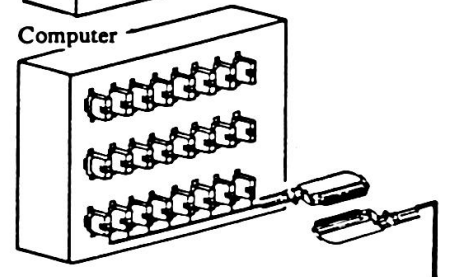

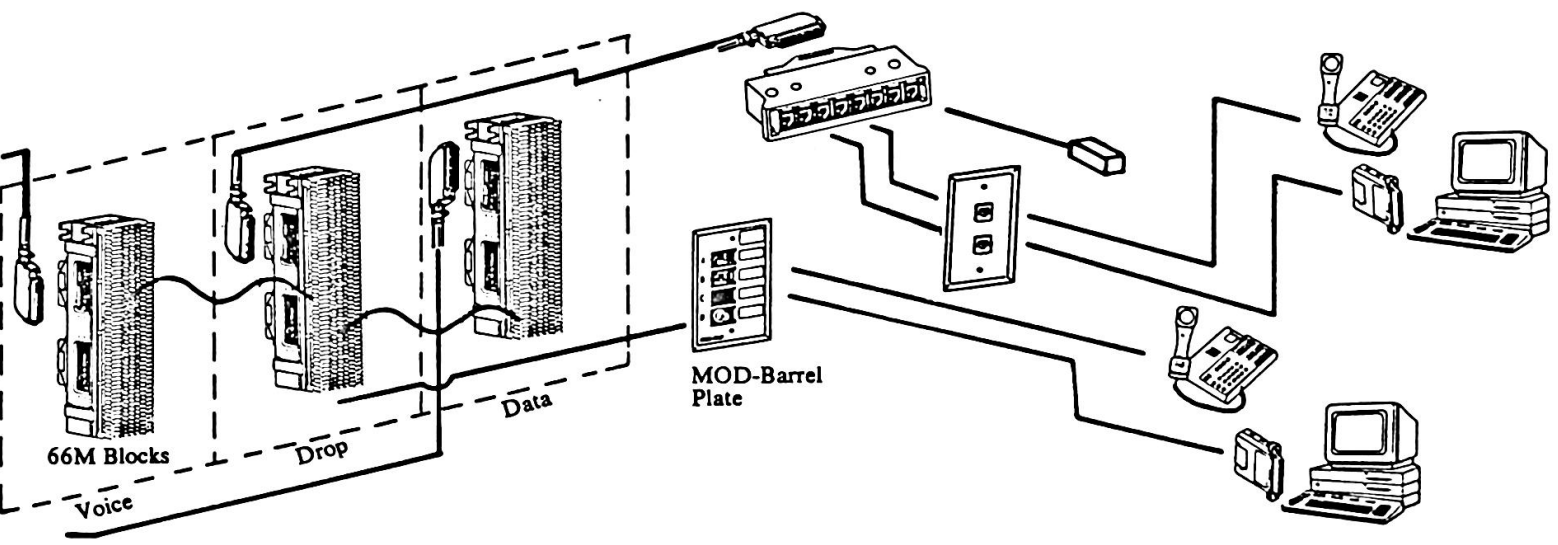
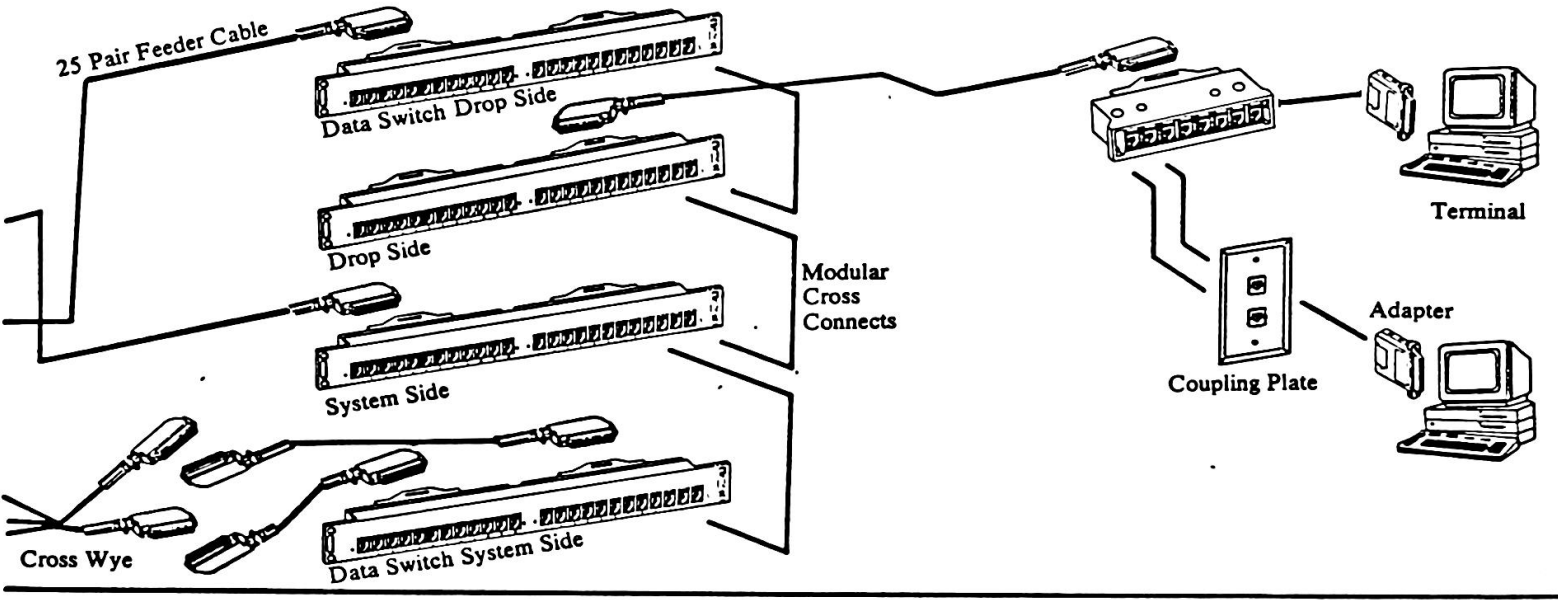
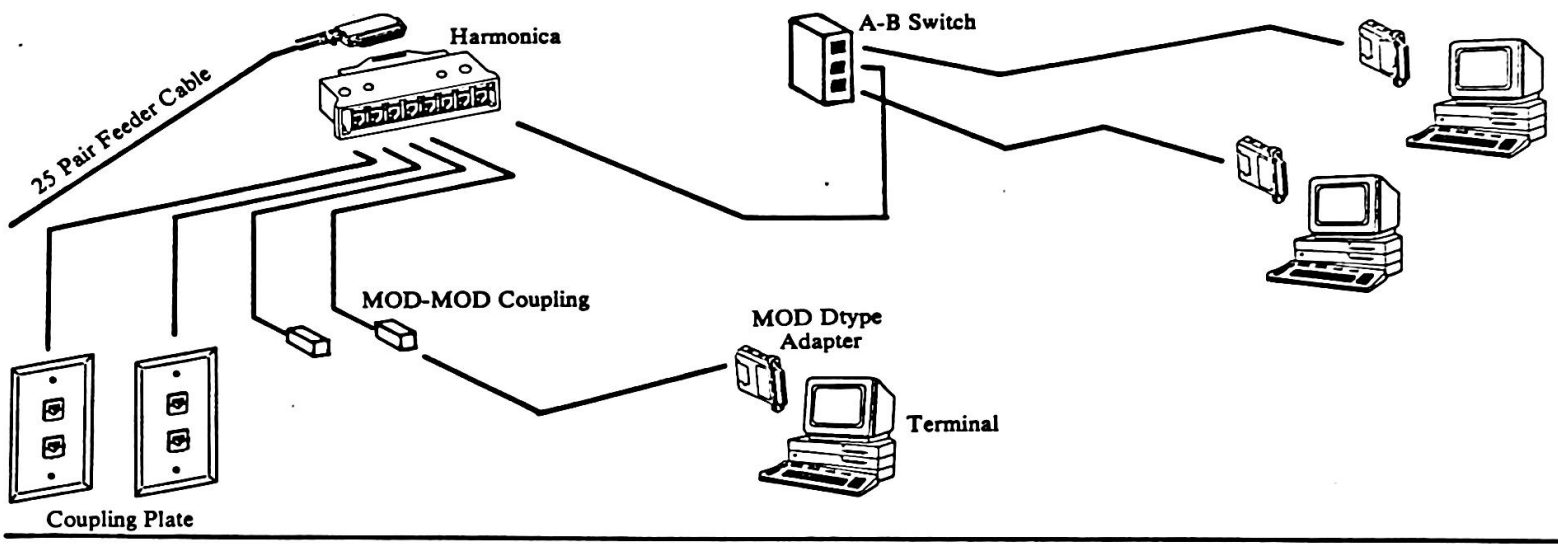

System Components

SYSTEM/DROP CONNECTIONS

MOD-BARREL PLATE

Provides up to 4 modular jacks in a one gang faceplate. Barrel connections simplify installation and reduce labor costs.

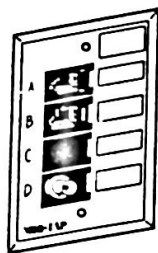

COUPLING PLATE

Used to provide wall mounting of connections to a Harmonica through modular cord.

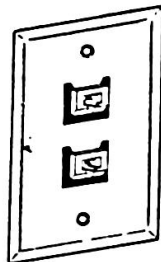

CROSS-WYEs

Designed and tested in conjunction with the Equipment Manufacturer, these harnesses convert the specific wiring scheme to the 50 position connector standard. Available for most major OEMs' equipment.

OCTOPUS

Converts a 50 position connector to individual 4, 6, or 8 wire modular cords. Used to connect multiple channel equipment to the MOD-TAP System.



HARMONICA

A 50 position male plug is wired to modular jacks to convert the 25 pair feeder cable into individual channels. Available in 4, 6, or 8 channel configurations.

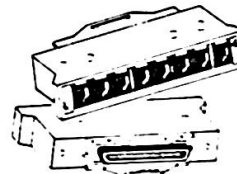

ADAPTERS

MOD-Dtype

MOD-Dtype Adapters are available in 25, 15, and 9 pin sizes in many wiring configurations. Modular line cords snap in and out quickly and easily.

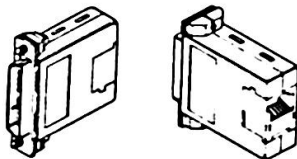

BALUNS

Adapts coaxial, twinaxial equipment to operate over the MOD-TAP System twisted pair media.

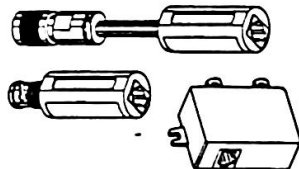

MOD-MOD ADAPTERS

Easily converts polarity, split lines, or change sex of modular connections. Available in 3 models and many wiring configurations.

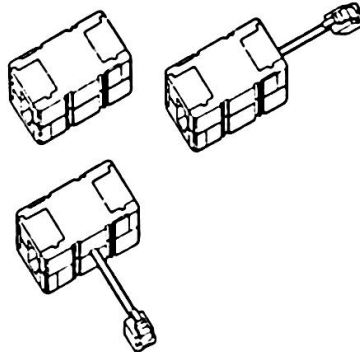

IBM ADAPTER

Interfaces equipment equipped with the IBM Data Connector to WECO format and to the MOD-TAP System.

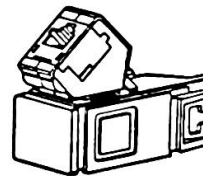

COUPLINGS

Connects two modular cords or provide a sex change with the same polarization.

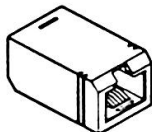

DISTRIBUTION SYSTEM EQUIPMENT

MOD-TEST GEAR

A complete line of test equipment for single channel or 25 pair multiple channel testing

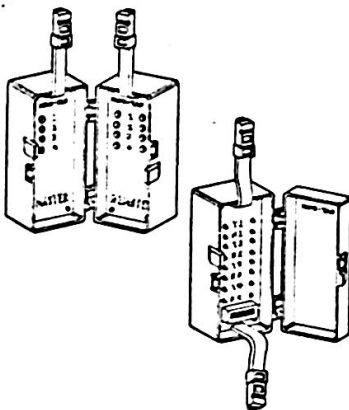

MODULAR PATCHING

Provides 24, 4, 6, or 8 wire channels in a single 1 3/4" high plate. Equipped with rear mounted 50 position connectors.

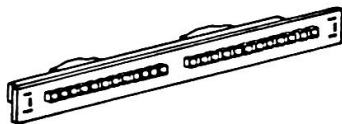

QUICK CONNECT BLOCKS

Available unwired or pre-wired to rear mounted 50 position connectors.

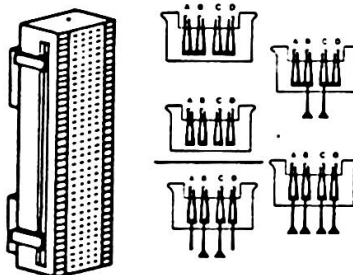

OPEN BAY RACK SYSTEM

A complete line of industry standard 19" rack equipment is available including frames, QC block mountings, shelves, and wire unspoolers.

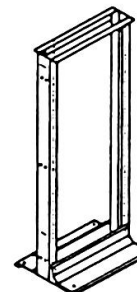

- 8.02 Distribution Frame
- 8.04 Cross Connect Apparatus
- 8.06 Feeder Cables
- 8.08 Wall Plates
- 8.10 Wiring Standards
- 8.12 Cable and Cord
- 8.14 MOD Adapters
- 8.16 Interfacing
- 8.19 Testers
- 8.22 Functional Characteristics
- 8.23 System Overview



8.02 Distribution Frame

Communications cabling from equipment is terminated and cross connected on Distribution Frames. A Frame can consist of one or more Open Bay Racks on which cross connect apparatus is installed.

The Open Bay Rack has 43 rack mounting positions, each 1 3/4 inches high. The top position is used for labeling the Bay. The remaining 42 positions can be divided into three Sections (top, middle, and bottom) of 14 rack positions each.

A Section will accommodate a Ring Run and 66M Module (holds 10 blocks), or 14 MOD Patch or Punched Panels, or 24-1/2 inches of rack-mount equipment.

The Racks segregate incoming cables terminated on the back from cross connects installed on the front.

In laying out multiple-bay Frames assign cable terminations so that the majority of cross connects will run bay-to-bay, horizontal-section to horizontal-section. It is good practice to leave one or more sections blank and available for future use.

Allow working access to front and rear of the Rack. Fasten each bay to the floor with lag bolts and brace the top to a parallel wall using Unistrut, or equivalent.

The 14 Position Wall Mounting should be securely attached to a wall with lag bolts.

The 2 Position Wall Mounting can be installed using toggle bolts or fiber anchors.

All tapped holes are 12-24 thread.

Dimensions inches (mm)

	A	B	C	D
Open Bay Rack	75.25 (1911)	84.00 (213)	15.00 (387)	20.40 (518)
14 position	22.25 (565)	28.00 (711)	12.75 (324)	20.40 (518)
2 position	3.00 (76)	3.50 (89)	4.00 (102)	19.00 (483)

Open Bay Rack
S 25-100

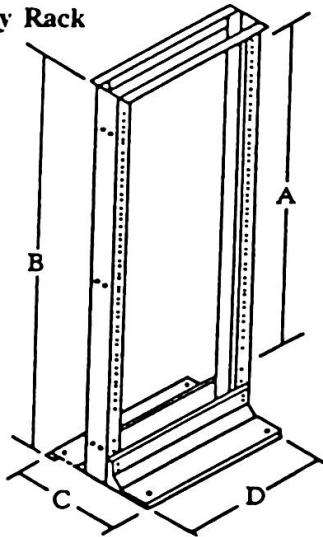

14 Position Wall Mounting
25-110

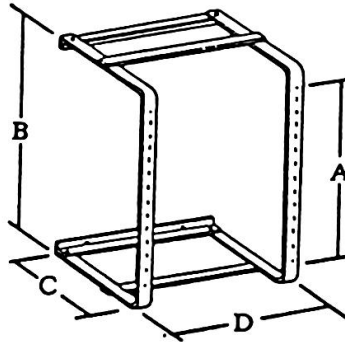

2 Position Wall Mounting
S 27-300

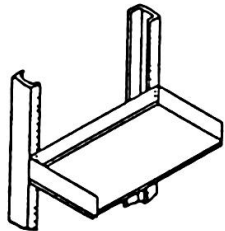
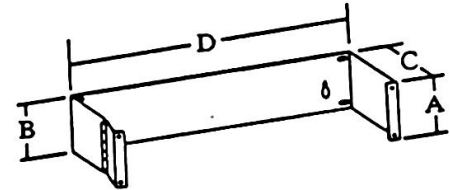

Desk
25-205
Occupies 2 rack positions

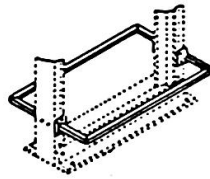

Guard Rail
25-201 (pair)

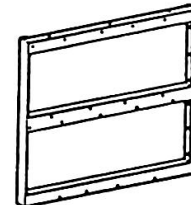

10M Module
S 25-208
Occupies 12 rack positions

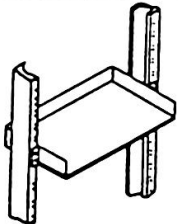

Shelf
25-204
Occupies 2 rack positions

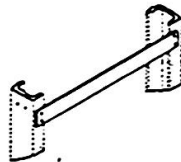

Blank Panels
S 25-211 1 position
25-217 7 position

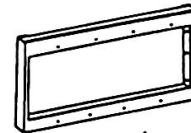

5M Module
25-208-5
Occupies 6 rack positions

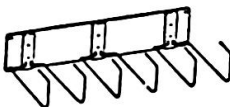

Ring Run
S 25-207
Occupies 2 rack positions

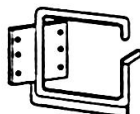

Cable Ring
35-401



Rack Screw
S 25-203
(100/pkg)

Distribution Frame 8.03

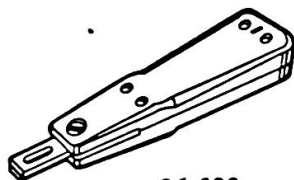
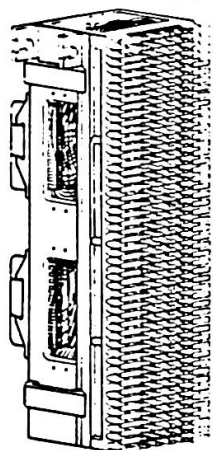

26-503
66M Tool

66M Blocks

The 66 Clip has been in use for over 20 years. It has a proven history as a versatile and reliable insulation displacement contact for #26 to #22 AWG solid conductor wire. The clip is rated for a minimum of 500 wiring cycles.

To terminate a conductor catch the wire on the clip and push down with the 66 Tool. The clip displaces the insulation and the tool trims excess wire length.

Blocks are available unwired or wired with 50-positions on the back or side. See page 8.05 for part numbers.

66M Blocks	qty/ Block	qty/ Section	qty/ Rack
25 Pair Block		10	30
2-wire pairs	25	250	750
4-wire channels	12	120	360
6-wire channels	8	80	240
8-wire channels	6	60	180
50 Pair Block		10	30
2-wire pairs	50	500	1000
4-wire channels	24	240	720
6-wire channels	16	160	480
8-wire channels	12	120	360
100 Pair Block		10	30
2-wire pairs	100	1000	3000
4-wire channels	48	480	1440
6-wire channels	32	320	960
8-wire channels	24	240	720

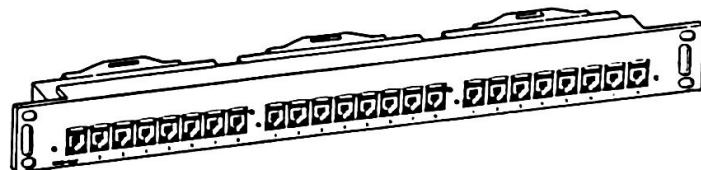
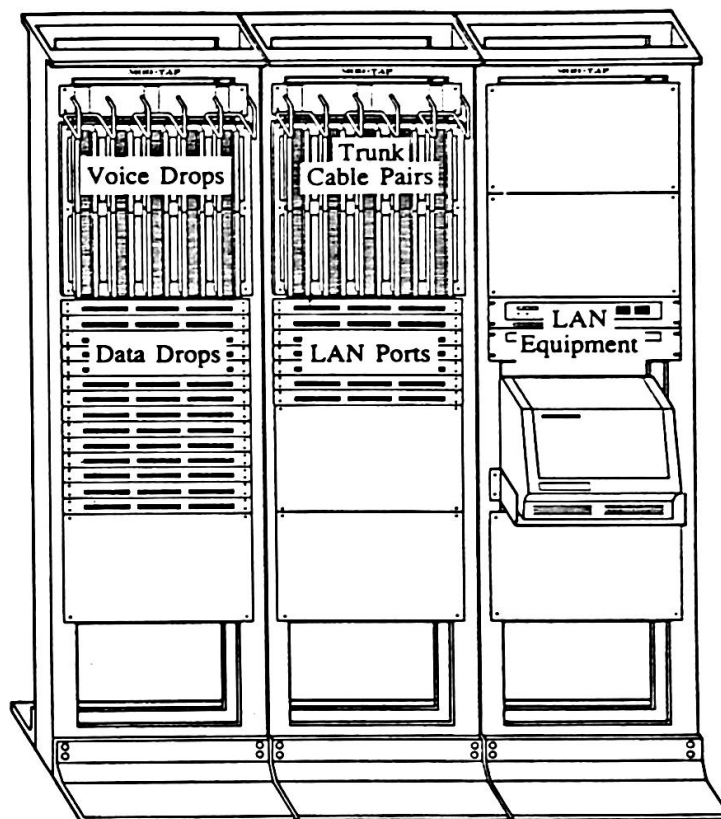

MOD Patch Panels

Patching provides a modular alternative for closet cross connects. A MOD Patch Panel is an enclosed assembly of 50-position connectors on the back wired to modular jacks on the front.

25 pair Feeder Cables attach to the 50-positions. Patch cords snap in and out of the modular jacks. See page 8.04 for part numbers.

MOD Patch Panels	qty/ Panel	qty/ Section	qty/ Rack
2-wire channels	25	350	1050
Feeders	1	14	42
4-wire channels	24	336	1008
Feeders	2	28	84
6-wire channels	24	336	1008
Feeders	3	42	126
8-wire channels	24	336	1008
25 pair Feeders	4	56	168

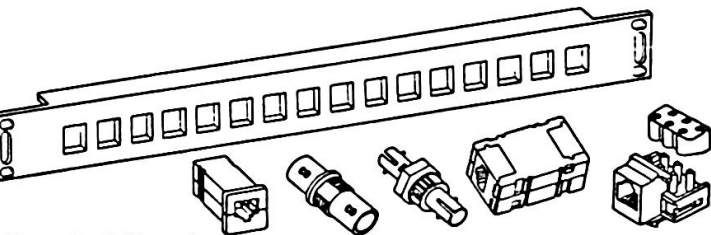

Punched Panels

Panels adapt MOD-FIT Jacks, MOD Couplings, BNC Couplings, Fiber Optic Couplings, and MOD MOD Adapters to 19 inch wide rack mounting. See page 8.04 for part numbers.

Punched Panels	qty/ Panel	qty/ Section	qty/ Rack
MOD Couplings	12	168	504
BNC Couplings	16	224	672
FIBER Couplings	12	168	504
MOD MOD Adapters	16	224	672
MOD-FIT Jacks	12	168	504

8.04 Cross Connect Apparatus

MOD Patch Panels

Each Panel occupies 1 mounting position in a 19 inch wide Rack.

50-position connectors on the back are wired to modular jacks on the front.

Velcro retainers are provided to secure mating cables to the panel's 50-position connectors.

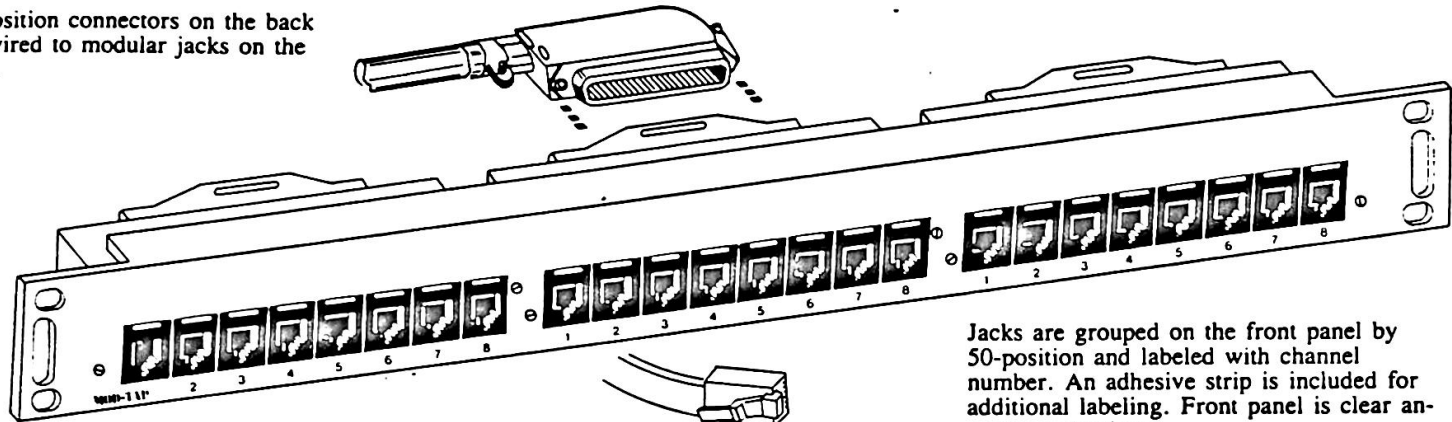

Modular Line Cords are used to patch any jack to any other jack. Order from page 19.

Jacks are grouped on the front panel by 50-position and labeled with channel number. An adhesive strip is included for additional labeling. Front panel is clear anodized aluminum.



27-224-20
2-wire 25-channel

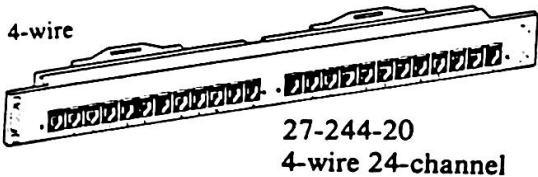

27-244-20
4-wire 24-channel

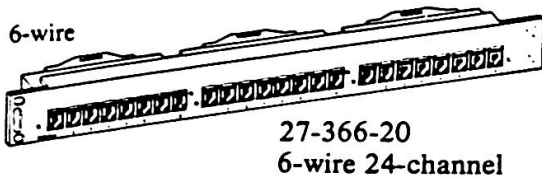

27-366-20
6-wire 24-channel

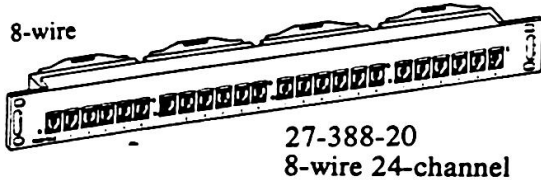

27-388-20
8-wire 24-channel

Standard 50-position sex is Female Connector. Number (#) and modular Polarization/Sequence of modular jacks as noted. Number of 50-positions per panel as noted.

Punched Panels

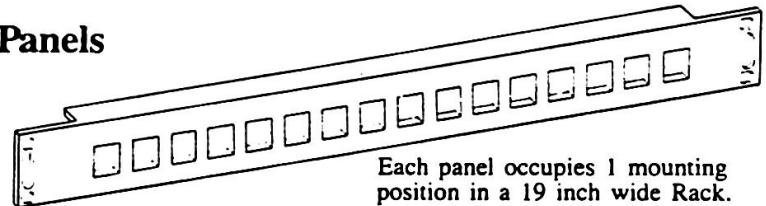

Each panel occupies 1 mounting position in a 19 inch wide Rack. Panels are clear anodized aluminum.

MOD-FIT Panels

MOD-FIT Jacks provide insulation displacement barrels for termination of #26 to #22 AWG solid or stranded conductors, Barrel Tool required. Panels include the specified quantity and style of MOD-FIT Jacks. Jacks snap into panel after conductor termination. LB indicates Large Barrel, SB indicates Small Barrel.



Coupling Panels

Panels include the specified quantity and style Couplings factory-mounted. MOD Couplings mate two modular plugs, BNC Couplings mate two BNC plugs, FIBR Couplings mate two fiber optic connectors (AT&T ST, 62.5 micron).



MOD MOD Panels

Panels include clips for mounting 16 MOD MOD Adapters. MOD MOD Adapters are used to mate two modular plugs. Order MOD MOD's separately from page 8.14.

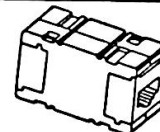

MOD Patch Panels

MOD-FIT Panels

Coupling Panels

MOD MOD Panels

# Wires/Channel	Part #	# of Ports	Polzn/Seq	# 50-Posn
2-wire	S 27-224-20	25	WE4W/STND	1
2-wire	27-616-24-20	16	WE4W/STND	1
4-wire	S 27-344-20	24	WE4W/STND	2
6-wire	27-365-23	24	WE6R/MMJ	3
6-wire	S 27-366-20	24	WE6W/STND	3
8-wire	27-388-21	24	WE8W/258A	4

Barrel Tools:	
S 39-917 LB	
S 39-916 SB	
30-421-5	16 WE6R SB Jacks
30-212-6	12 WE6W LB Jacks
S 30-212-8	12 WE8W LB Jacks

Other:	
30-418-A	16 BNC
30-219-F	12 FIBR
30-411-6	16 WE6W
S 30-411-8	16 WE8W

30-310
16 hole panel

Cross Connect Apparatus 8.05

66M Blocks

The M Block has four columns of fifty 66 Clips each. A mounting Bracket is included with each Block. Ten Brackets and Blocks install on a 66M Module (shown on page 4) for 19 inch Rack mounting.

Fanning strips, running down both sides of the front face, provide space for labeling with a fine point marker.

A snap-on clear plastic cover is available. It provides additional labeling area as well as protection of the clips and wiring.

The 66 Tool is required to terminate wires on the clips.

Bridging clips are used to jumper one or more clips in one column to clips in an adjacent column.

Cross Wire is used to cross connect any set of 66 Clips to any other set. Cross Wire is #24 AWG solid Cu conductor, paired, twisted, and bandstripe color coded, no overall jacket.

Connectorized Termination

Use 100C4 Block. Feeders are attached to 50-positions wired to columns A, B, C, and D. Cross Wire is installed on columns A, B, C, and D. Terminates 100 pairs per block.

Cutdown Termination

Use 50UW Block. Cable pairs are cutdown on columns A and D. Cross Wire is installed on columns B and C. Terminates 50 pairs per block.

Half Connectorized Fixed Splice

Use 100C4 Block. Cable pairs are cutdown on columns A, B, C, and D. Feeders are attached to 50-positions wired to columns A, B, C, and D. Splices 100 pairs per block.

Half Connectorized

Flexible Splice

Use 50C1 Block. Cable pairs are cutdown on column D. A Feeder is attached to the 50-position wired to columns A and B. To splice, install Bridging Clips across columns B and C. Either side of the splice may be cross connected to other clips by removing the bridging clips and installing Cross Wire on columns B and/or C. Splices 25 pairs per block.

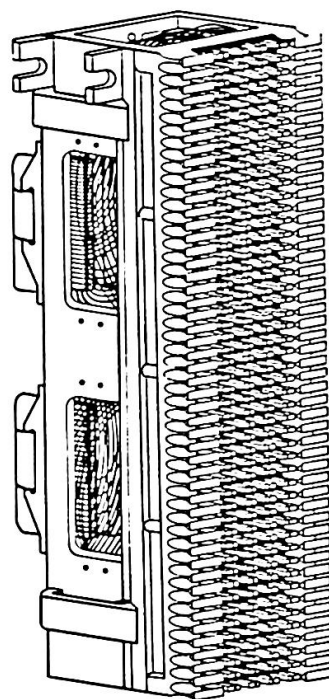

Wired Blocks

Rear mounted female connectors

50C1 26-211
50 pairs of double clips, 1 connector

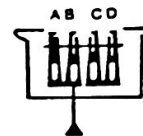

50C2 S 26-201
50 pairs of double clips, 2 connectors

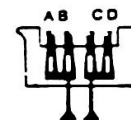

100C2 26-311
100 pairs of single clips, 2 connectors

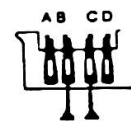

100C4 S 26-301
100 pairs of single clips, 4 connectors

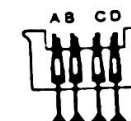

Unwired Blocks

Block and Bracket only

50UW S 26-101
50 pairs of double clips

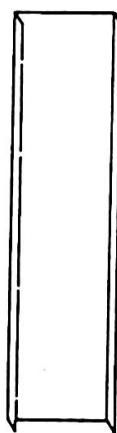

Cover
S 26-002

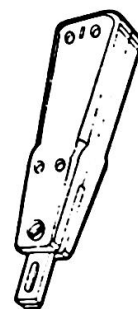

66 Tool
S 26-503

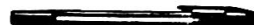

Fine Point
35-601

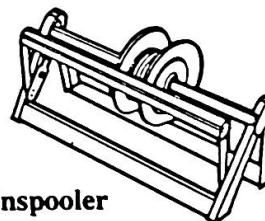

Unspooler
26-601

Bridging Clips

S 26-400 1-wire
26-402 2-wire
26-404 4-wire
26-406 6-wire
26-408 8-wire



Cross Wire

S 26-902 2-wire
S 26-904 4-wire
S 26-906 6-wire
26-908 8-wire

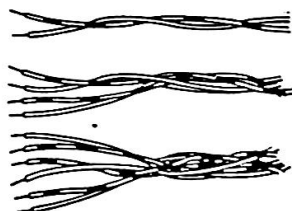

8.06 Feeder Cables

System Connects

A device with multiple channels is defined as a System Equipment. Computer front ends, LAN Nodes, Voice Switches, Data Switches, Multiplexers, and Modem clusters are typical System Equipment.

Multiple channel Feeder Cables are run from System Equipment to a Distribution Frame. Ends are wired with 50-position connectors. A System Connect is used to adapt the Feeder's 50-position to the Equipment's Interface.

If the Equipment has each channel on an individual connector use an Octopus with MOD Adapters. If the equipment has multiple channels on a single connector use a CrossWye.

Multiple Channel Connectors
Use a CrossWye
(see page 24)

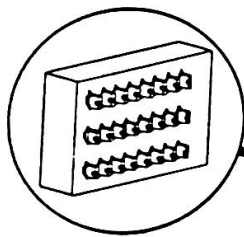

Individual Channel Connectors
Use an Octopus

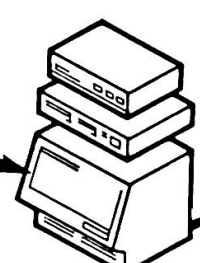
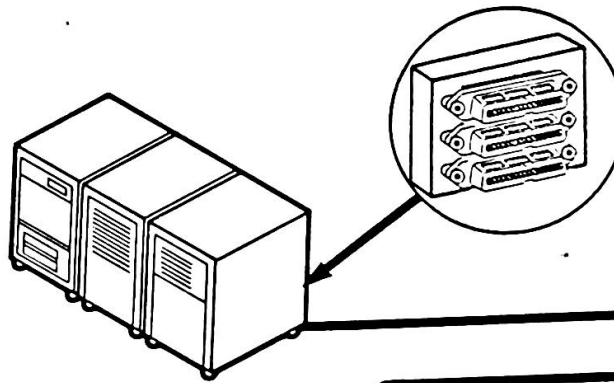

Feeder Cables

Feeder Cables are Inside Wire Cable (IWC), 25 pair, PVC or FRD construction. Specifications on page 18.

Install Feeders so that Distribution Frame end is wired with a Male 50-position Plug and the other end is wired with a Female 50-position Connector.

Running Feeders are specified for long cable pulls and for feeders run in raceway. Cable is shipped on 1000 foot disposable reel. 50-positions are field wired to Feeder ends after pulling. Butterfly Tool required.

Prewired Feeders are used for short cable runs, for extending Feeders, and for 50-position sex change.

Running Feeders

Standard put-up is 1000 feet on disposable reel.

Pair Count	IWC-PVC	IWC-FRD
25	S 39-125	39-225

50-Positions

Use the Butterfly Tool to field wire these 50-position plugs and connectors to 25 pairs in one shot.

Prewired Feeders

P is male Plug, C is Female Connector

	Feet	IWC-PVC	IWC-FRD
← PC	10	S 40-110-12	40-210-12
	30	S 40-130-12	40-230-12
	50	S 40-150-12	40-250-12
← PP	100	40-100-12	40-200-12
	1	S 40-101-11	40-201-11
	10	40-110-11	40-210-11
← CC	30	40-130-11	40-230-11
	50	40-150-11	40-250-11
	100	40-100-11	40-200-11
← CC	1	S 40-101-22	40-201-22
	10	40-110-22	40-210-22
	30	40-130-22	40-230-22
← CC	50	40-150-22	40-250-22
	100	40-100-22	40-200-22

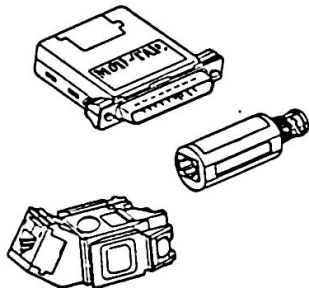

MOD Adapters
on page 21.

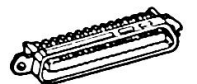
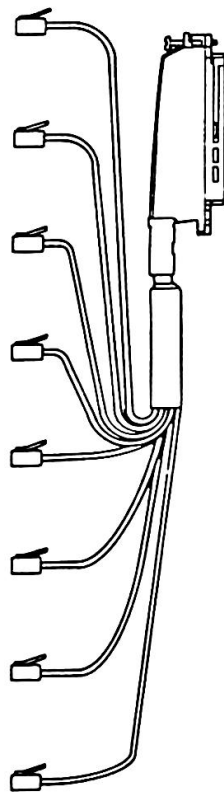

Male Plug
S 40-011

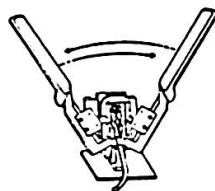

Butterfly Tool
40-010

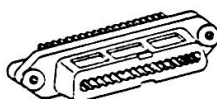

Female Connector
S 40-012

Octopus

The Octopus breaks out a Feeder Cable onto modular plugs. Standard overall length is 2 feet, legs are WE type modular cord. Standard 50-position sex is Male Plug. Number (#) of plugs and modular Polarization and Sequence as noted.

# Wires Channel	Part #	# of Legs	Polzn/Seq
2-wire	24-224-10	25	WE4W/STND
4-wire	S 24-244-10	12	WE4W/STND
6-wire	24-265-13	8	WE6R/MMJ
6-wire	S 24-266-10	8	WE6W/STND
8-wire	24-288-10	6	WE8W/STND
8-wire	24-288-11	6	WE8W/258A

Feeder Cables 8.07

Demountable Drops

Single channel attachment points to the Horizontal Wiring are called Drops.

Demountable Drops are used with modular furniture systems and for temporary hook-ups. Components snap together, snap apart.

Multiple channel Feeder Cables are run from Distribution Frame to furniture islands. Ends are wired with 50-position connectors. A Harmonica is attached to the Feeder end. Drop Runs are installed from the Harmonica to the office Drops.

A Power Pole can be used to route the Feeder from ceiling plenum to the furniture wireway. Feeders may alternately be installed in floor duct or poked-through from below. Do not attach 50-positions until cable has been routed into wireway.

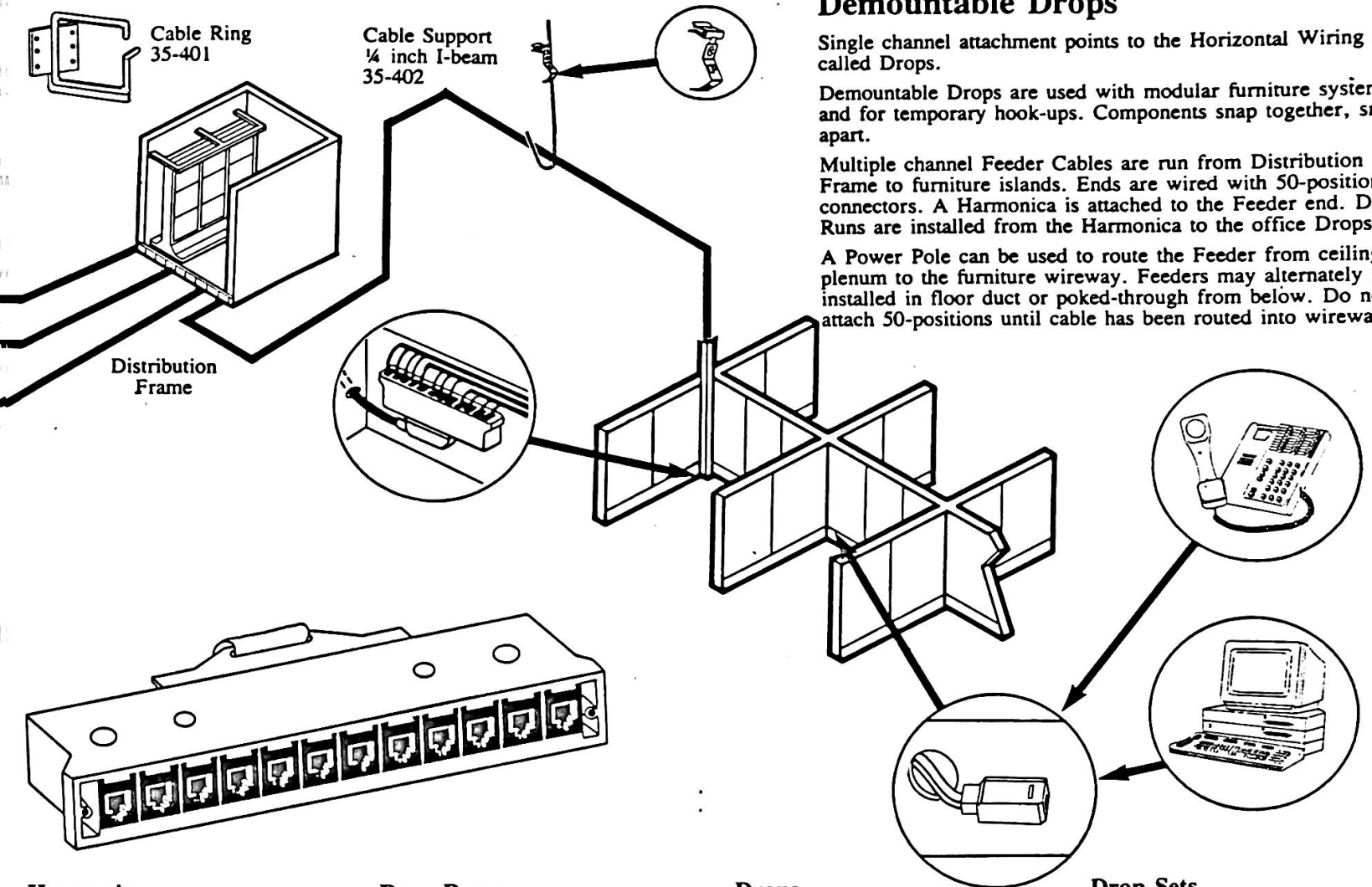

Harmonica

The Harmonica breaks out a Feeder Cable onto modular jacks. Standard 50-position sex is Male Plug. Number (#) of jacks and modular Polarization/Sequence as noted. With Feeder Cable attached the Harmonica is no larger than

H W D
inches 8.10 2.50 1.07
(cm) (206) (64) (27).

Harmonica Cover magnetic 21-820
Ferrous Plate 21-810

Drop Runs

Short runs of WE style cord or Inside Wire Cable (IWC) from Harmonica to Drop. Field-wired with modular plugs. Modular Tool and Die Required. Alternately, prewired Line Cords may be used, page 8.12

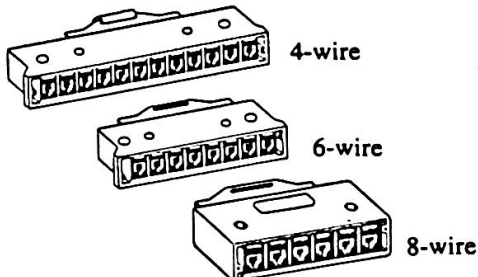

Drops

The Drop is a modular-to-modular MOD MOD Adapter or Coupling. It is the demarcation point between the wiring grid and the equipment Drop Set.

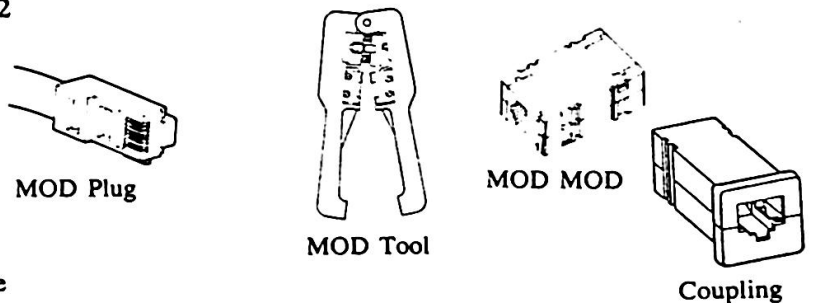

Drop Sets

One end of the Drop Set attaches the Drop. The other end attaches to the equipment. For Data Terminals the Drop Set typically consists of a modular Line Cord and MOD Adapter.

Harmonica

#Wires/Channel	Part #	# of Ports	Polzn/Seq
4-wire	S 22-344-10	12	WE4W/STND
6-wire	22-365-13	8	WE6R/MMJ
6-wire	S 22-366-10	8	WE6W/STND
8-wire	S 22-388-10	6	WE8W/STND
8-wire	22-388-11	6	WE8W/258A

Drop Run

MOD Cord	IWC/PVC	IWC/FRD	MOD Plug
S 03-314	S 39-102	39-202	S 02-554
S 03-316	S 39-103	39-203	S 02-555
S 03-316	S 39-103	39-203	S 02-556
S 03-318	S 39-104	39-204	S 02-558
S 03-318	S 39-104	39-204	S 02-558

Drop

MOD MOD	Coupling
09-200-550	S 10-660
	S 10-660
	S-10-880
	S 10-880

8.08 Wall Plates

US1

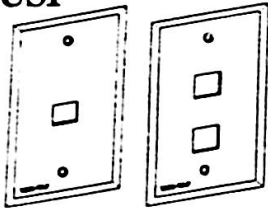

Unless otherwise noted, US1 Plates are brushed stainless steel for mounting on a single gang US electrical box.

Plates include two 6-32 x 5/8 inch chrome plated screws.

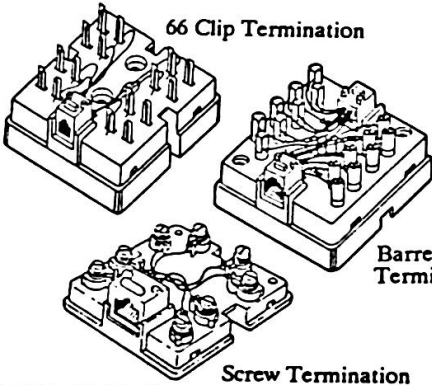

MOD BLOCK

Beige plastic. Mounts on any flat surface. Choice of 66 Clip (66 Tool required) or screw terminations. Two channel version uses large barrel contacts.

- 12-126 WE6W 66 Clips
- 12-128 WE8W 66 Clips
- 26-503 66 Tool
- 12-116 WE6W Screws
- 12-118 WE8W Screws

Two Channel Blocks

- 12-285 WE8W WE6R
- 12-286 WE8W WE6W
- 39-917 Large Barrel Tool

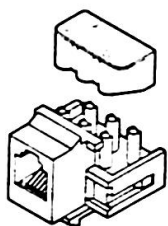

Barrels:
LB Large
SB Small

MOD-FIT Plates

Punched with 1 or 2 holes for MOD-FIT Jacks. Order Jacks separately. LB Barrel Tool required. 1-1/2 inches depth behind plate required.

- 16-112 1 MF hole
- 16-212 2 MF holes
- 01-046 WE6W LB Jack
- 01-048 WE8W LB Jack
- 01-045 WE6R SB Jack
- S 39-917 LB Tool

Coupling Plate

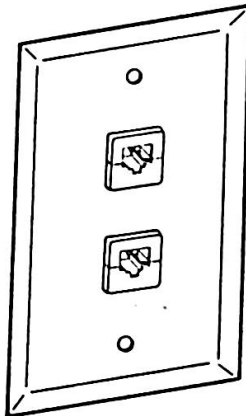

Plates include the specified quantity and style Couplings factory-mounted. 1-1/2 inch depth behind plate required.

14 series. See chart at right for examples of some configurations.

MOD Screw Plate

Beige plastic. Screw terminations. 1-1/2 inches depth behind plate required.

- S 19-101 1 WE6W
- S 19-104 2 WE6W

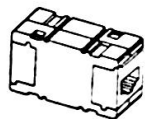
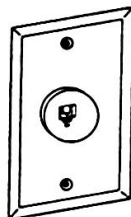

MOD MOD Plates

Punched with 1 or 2 holes for MOD MOD Adapters. Plate includes mounting clips. Order MOD MODs from page 20. 2-1/2 inches depth behind plate required.

- 16-110 1 MMA hole
- 16-210 2 MMA holes
- 34-141 Clips 100/pkg

Mod Coupling mate two modular plugs, BNC couplings mate two BNC plugs, FIBER couplings mate two AT&T/ST 62.5 micron Fiber Optic connectors. MOD MOD Adapter fits MMA hole (clips included). Order separately from page 8.14.

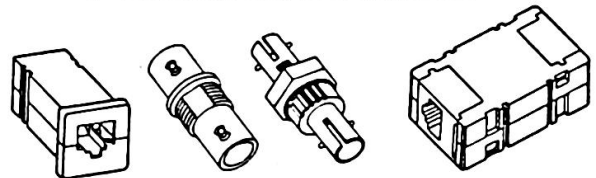

	WE6W	WE8W	BNC	FIBER	MMA hole
14-600	1				
14-660	2				
14-800		1			
S 14-880		2			
14-680	1	1			
14-A00			1		
14-AA0			2		
14-F00				1	
14-FF0				2	
14-601	1				1
14-801		1			1
14-A01			1		1
14-F01				1	1



MOD M Plate

Off white plastic. Provides 66M Clip terminations to 1 or 2 modular jacks.

66M Tool required, see page 8.05

- 60-20-88 WE8W WE8W
- 60-20-86 WE8W WE6W
- 60-20-55 WE6R WE6R
- 60-20-85 WE8W WE6R

MOD Duplex

Made of black plastic. Provides Large Barrel terminals for one or two modular jacks. Also available with BNC coupling.

- 19-2*-65 WE6W WE6R
- 19-2*-85 WE8W WE6R
- 19-2*-86 WE8W WE6W
- 19-2*-89 WE8W WE8K

*0 = Duplex Mounting
1 = Box Mounting

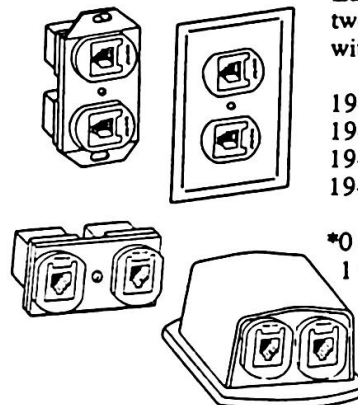

Fixed Wall Offices

When Drops are installed in fixed-wall offices a Home Run cable is installed from Distribution Frame to each office.

A Mounting is provided on the office wall. Specify a single gang US electrical box.

The Home Run is terminated on a Wall Plate and the Wall Plate is installed on the Mounting.

The Wall Plate is the demarcation point between the wiring grid and an equipment Drop Set.

To Distribution Frame

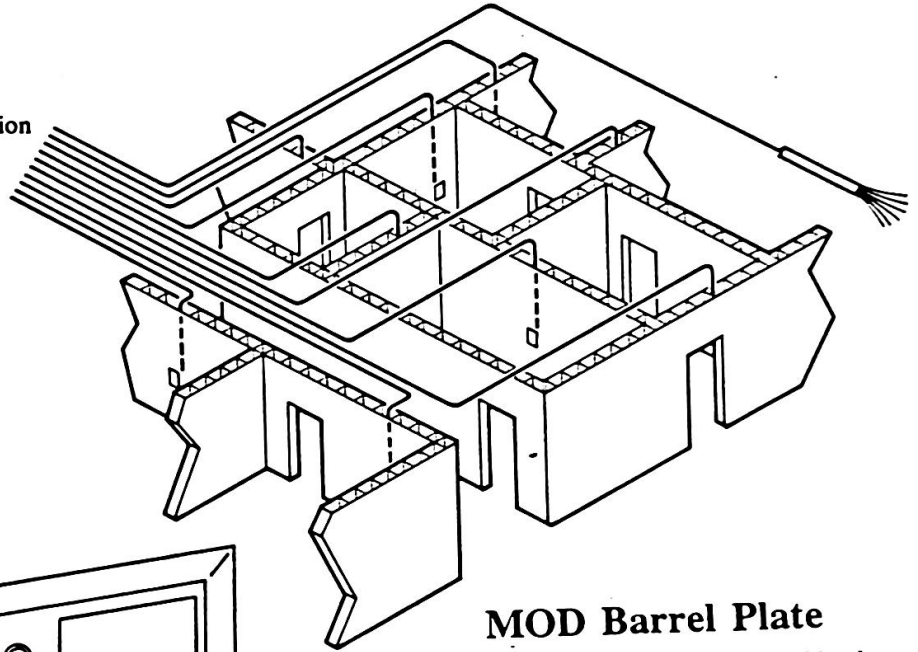

Mountings

Surface Box is 1- $\frac{3}{4}$ inches deep. The Extension Yoke adds $\frac{1}{4}$ inch depth to any box.

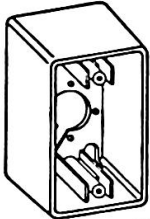

Surface Box
15-101

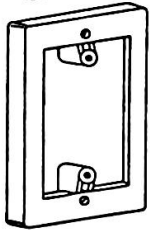

Extension Yoke
15-102

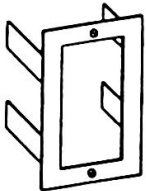

Drywall Bracket
15-103

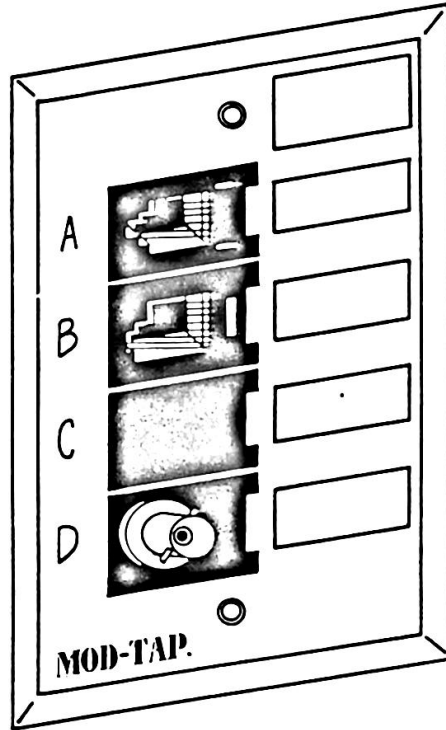

MOD Barrel Plate

The MOD Barrel Plate provides barrel terminations for up to four modular jacks, or for two modular jacks and either a coaxial or fiber optic Coupling.

Off White plastic color. 1 $\frac{1}{2}$ inch depth behind plate required. SB Barrel Tool required.

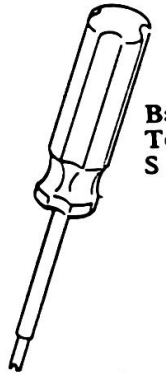

Barrel Tool SB
S 39-916

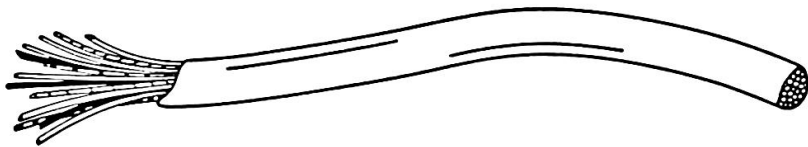

Home Runs

PVC or FRD Inside Wire Cable, pair count as required. BNC or FIBER cable may also be terminated on a MOD Barrel Plate.

	IWC-PVC	IWC-FRD
2-pair	S 39-102	39-202
3-pair	S 39-103	39-203
4-pair	S 39-104	39-204
6-pair	S 39-106	39-206
12-pair	S 39-112	39-212
25-pair	S 39-125	39-225

Plate Position	18-20-6080	18-20-6050	18-40-8855	18-40-8888	18-60-850A
A	WE6W	WE6W	WE8W	WE8W	WE8W
B	Blank	Blank	WE8W	WE8W	WE6R
C	WE8W	WE6W	WE6R	WE8W	Blank
D	Blank	Blank	WE6R	WE8W	BNC

Note: Other configurations available.

8.10 Wiring Standards

Schedule 0

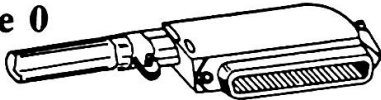

50-position to 25 Pair Wiring

There is only one 50-position to 25-pair wiring standard in the communications industry. We define it as Schedule 0.

25-pair Color is band-stripe color code. Each conductor has a dominant band and a thin stripe. A pair has matching opposite band-stripe combinations, for Pair 1, WHT/BLU color:

Tip (T) is mostly White (band) with a Blue stripe.
Ring (R) is mostly Blue (band) with a White stripe.

Tip (T) Bands		Ring (R) Bands	
White	WHT	BLU	Blue
Red	RED	ORG	Orange
Black	BLK	GRN	Green
Yellow	YEL	BRN	Brown
Violet	VLT	SLT	Slate

CDR is the 25 pair conductor designation.

CH-CDR is the channel (first two digits) dash channel conductor designation.

50-position		25 pair		4-wire	6-wire	8-wire
Pair	Pin	Color	CDR	CH-CDR	CH-CDR	CH-CDR
1	26	WHT	1T	01-T1	01-T1	01-T1
	1	BLU	1R	-R1	-R1	-R1
2	27	WHT	2T	-T2	-T2	-T2
	2	ORG	2R	-R2	-R2	-R2
3	28	WHT	3T	02-T1	-T3	-T3
	3	GRN	3R	-R1	-R3	-T3
4	29	WHT	4T	-T2	02-T1	T4
	4	BRN	4R	-R2	-R1	-R4
5	30	WHT	5T	03-T1	-T2	02-T1
	5	SLT	5R	-R1	-R2	-R1
6	31	RED	6T	-T2	-T3	-T2
	6	BLU	6R	-R2	-R3	-R2
7	32	RED	7T	04-T1	03-T1	-T3
	7	ORG	7R	-R1	-R1	-R3
8	33	RED	8T	-T2	-T2	-T4
	8	GRN	8R	-R2	-R2	-R4
9	34	RED	9T	05-T1	-T3	03-T1
	9	BRN	9R	-R1	-R3	-R1
10	35	RED	10T	-T2	04-T1	-T2
	10	SLT	10R	-R2	-R1	-R2
11	36	BLK	11T	06-T1	-T2	-T3
	11	BLU	11R	-R1	-R2	-R3
12	37	BLK	12T	-T2	-T3	-T4
	12	ORG	12R	-R2	-R3	-R4
13	38	BLK	13T	07-T1	05-T1	04-T1
	13	GRN	13R	-R1	-R1	-R1
14	39	BLK	14T	-T2	-T2	-T2
	14	BRN	14R	-R2	-R2	-R2
15	40	BLK	15T	08-T1	-T3	-T3
	15	SLT	15R	-R1	-R3	-R3
16	41	YEL	16T	-T2	06-T1	-T4
	16	BLU	16R	-R2	-R1	-R4
17	42	YEL	17T	09-T1	-T2	05-T1
	17	ORG	17R	-R1	-R2	-R1
18	43	YEL	18T	-T2	-T3	-T2
	18	GRN	18R	-R2	-R3	-R2
19	44	YEL	19T	10-T1	07-T1	-T3
	19	BRN	19R	-R1	-R1	-R3
20	45	YEL	20T	-T2	-T2	-T4
	20	SLT	20R	-R2	-R2	-R4
21	46	VLT	21T	11-T1	-T3	06-T1
	21	BLU	21R	-R1	-R3	-R1
22	47	VLT	22T	-T2	08-T1	-T2
	22	ORG	22R	-R2	-R1	-R2
23	48	VLT	23T	12-T1	-T2	-T3
	23	GRN	23R	-R1	-R2	-R3
24	49	VLT	24T	-T2	-T3	-T4
	24	BRN	24R	-R2	-R3	-R4
25	50	VLT	25T	OW-T	OW-T	OW-T
	25	SLT	25R	-R	-R	-R

(Order Wire channel, OW, is spare.)

Sequence

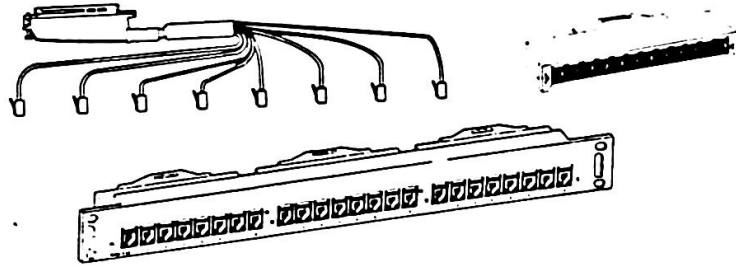

50-position to Modular Wiring

The 50-position to modular pin wiring in such components as the Harmonica, Octopus, and MOD Patch Panel is called the Sequence. There are four standard Sequences in use today: STND, MMJ, 258A, and BT.

STND

This is the original US voice communications industry standard. Most Voice equipment is compatible with this Sequence. Available in WE4W, WE6W, WE8W and WE8K modular polarizations 4-, 6-, and 8-wire channels.

Channel Conductor	8-wire MODpin	6-wire MODpin	4-wire MODpin
T1	5	4	4
R1	4	3	3
T2	3	2	2
R2	6	5	5
T3	2	1	
R3	7	6	
T4	8		
R4	1		

MMJ

This is an adaptation of STND especially suited to asynchronous RS232 and RS423 Interface Data equipment. Available in WE6R Polarization 4- or 6-wire channels.

Channel Conductor	6-wire MODpin
T1	2
R1	3
T2	5
R2	4
T3	1
R3	6

258A

This is an adaptation of STND used by AT&T. 8-wire channels in WE8W or WE8K Polarizations.

Channel Conductor	8-wire MODpin	AT&T Designation
T1	5	TT
R1	4	TR
T2	1	BT
R2	2	BR
T3	3	AT
R3	6	AR
T4	7	LT
R4	8	LR

BT

This is the British Telecom standard for their BT4L, BT6L, BT4H and BT6H Polarizations. Available 4- and 6-wire.

Channel Conductor	6-wire MODpin	4-wire MODpin
T1	5	5
R1	2	2
T2	3	3
R2	4	4
T3	6	
R3	1	

Wiring Standards 8.11

Normal/Reverse

Modular to Modular Wiring

Modular-to-modular apparatus such as Couplings, Line Cords, and MOD MOD Adapters can be wired either Normal or Reverse between modular ends. Unless otherwise noted all apparatus is wired Normal.

Normal color coded White

Straight-through wiring

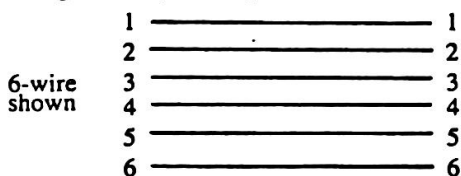

8-wire		6-wire		4-wire	
MOD pin	MOD pin	MOD pin	MOD pin	MOD pin	MOD pin
1	1				
2	2	1	1		
3	3	2	2	2	2
4	4	3	3	3	3
5	5	4	4	4	4
6	6	5	5	5	5
7	7	6	6		
8	8				

Reverse color coded Red

Criss-cross wiring

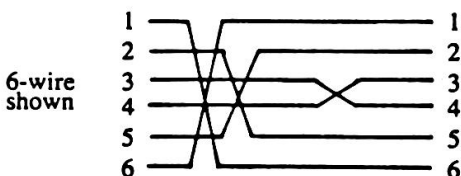

8-wire		6-wire		4-wire	
MOD pin	MOD pin	MOD pin	MOD pin	MOD pin	MOD pin
1	8				
2	7	1	6		
3	6	2	5	2	5
4	5	3	4	3	4
5	4	4	3	4	3
6	3	5	2	5	2
7	2	6	1		
8	1				

Polarization

Modular Jack/Plug Style

There are several polarization styles. A plug from one style will not mate to a jack from another style.

WE4W
WE6W
WE8W
etc.

Western Electric

USOC RJ-series with the locking tab centered below the MOD pins.

WE4W 4-wire
WE6W 6-wire
WE8M 8-wire Milled (plug only)
WE8W 8-wire
WE8K 8-wire with Key

Plug to Jack possibilities

Plug	WE8K	WE8W	WE6W	WE4W
WE4W	WE8K	WE8W	WE6W	WE4W
WE6W	WE8K	WE8W	WE6W	WE4W
WE8M	WE8K	WE8W	WE6W	WE4W
WE8W	WE8K	WE8W		
WE8K	WE8K			

WE6R Western Electric Right (MMJ)

Digital Modified Modular same as WE-W except locking tab is shifted right.

WE4R 4-wire
WE6R 6-wire
WE8R 8-wire

Plug to Jack possibilities

Plug	WE8R	WE6R	WE4R
WE4R	WE8R	WE6R	WE4R
WE6R	WE8R	WE6R	WE4R
WE8R	WE8R		

BT4L
BT6L

British Telecom Line

Locking tab on top, MOD pins 90 degrees left.

BT4L 4-wire (plug only)
BT6L 6-wire

Plug to Jack possibilities

Plug	BT6L
BT4L	BT6L
BT6L	BT6L



WE4W



WE6W



WE8W



WE8K



WE6R



BT6L

ISDN -

The AT&T S/T Interface Part IIA (5D5-900-301, 9/85) specifies that ISDN in the building environment will be point-to-point, operating over twisted pairs, 4 wires minimum, 8 wires maximum, per channel.

The four data signals are mandatory. They may also be used to provide phantom power from NT to TE, CCITT power option 1. If only these signals are used then AT&T S/T will operate over 4-, 6-, or 8-wire channels, STND or 258A Sequence.

The PowerIn signals may be used to provide power from NT to TE per CCITT Power Option 2. The PowerOut signals may be used to provide power from TE to NT (not a CCITT Power Option). If either PowerIn or PowerOut signals are used then 8-wire 258A Sequence should be specified.

TE to NT and TE to TE connections are allowed, for the later case use a Reverse in the channel.

ISDN S/T equipment is defined as either
TE Terminal End, wired Normal on Equipment
NT System End, wired Reverse on Equipment

WE8W MODpin on Equipment

TE Normal	NT Reverse	ISDN Signal
1	8	PowerOut+
2	7	PowerOut-
3	6	DataOut+
4	5	DataIn+
5	4	DataIn-
6	3	DataOut-
7	2	PowerIn-
8	1	PowerIn+

8.12 Cable and Cord

ShopTalk

There are three types of cable used for communications wiring. In general, Coaxial and Fiber Optic cables are used for closet-to-closet cabling of the vertical LAN Backbone. In general, Twisted Pair is used for vertical closet-to-MDF cabling of the Copper Backbone and for horizontal closet-to-desk Drop cabling.

Two styles of Twisted Pair cable are used in building wiring. Aerial/Duct Cable (A/D) is large pair-count Trunk cable. It is used closet-to-MDF. Inside Wire Cable (IWC) is available in pair-counts of 2 to 25. It is used for closet-to-desk cabling.

IWC is available in either PVC or FRD construction. FRD construction is of a fluoropolymer material such as DuPont's TEFLON. The material has low smoke/low flame characteristics. PVC construction is of polyvinyl chloride material. In general, PVC is run in raceway or in open air in open air plenums. In general, FRD is run in open air in forced air plenums.

IWC Specification

IWC shall meet or exceed REA Specification PE-71. It shall be band-stripe color coded. It shall have an overall outside jacket. Conductor shall be #24 AWG solid Cu. Conductors shall be paired. Twists per foot shall be different for each pair within the range of 2 to 12 twists per foot.

IWC Lab Data

Cable conforming to IWC Specification should measure:

0.017 mF/Mft	average mutual capacitance at 1KHz
27 ohms/Mft	maximum conductor resistance at 68F
8 dB/Mft	maximum signal attenuation at 1MHz
2500 VDC	Dielectric signal strength, 3 second minimum, conductor-to-conductor

Shielding

An overall cable shield, installed just under the cable jacket, is standard on A/D cable and available on IWC cable. The purpose of the shield is to isolate the cable's conductors from surrounding electrical noise. Overall shielded IWC cable is seldom required. In general, if ambient noise does not affect Voice it will not affect Data.

When shielded cable is used the shield should be installed so that it is contiguous end-to-end. Ground one end of the shield and float the other. It is good practice to ground all shields at only one point.

Mixing Cable

Cables have characteristic impedances which vary according to the cables' physical parameters. When cables of different characteristic impedances are mixed an impedance imbalance will occur. It is bad practice to mix wire gauges or twisted and non-twisted pair cables. However, it is accepted practice to combine long runs of twisted pair cable with short lengths of modular Patch Cords and Line Cords, except with Baluns (see page 21).

Attenuation

As a signal travels along a conductor it weakens, or attenuates. If the signal attenuates beyond its Interface threshold it will be lost. Most Data Interface specifications allow for about 20 dB end-to-end attenuation.

Cross Talk

Within a pair, Cross Talk is unwanted energy radiated from one conductor to its mate. For Twisted Pair Data Interfaces it is bad practice to run DataIn and DataOut leads in the same pair. It is good practice to pair each Data lead with signal ground (or in the alternate, a relatively dormant control lead).

Within a cable, Cross Talk is unwanted energy radiated from one pair to another pair or conductor. It is best practice to use balanced Interfaces which employ signalling specifically to minimize Cross Talk. It is accepted practice to use unbalanced Interfaces over distances of 500 to 1000 feet.

Coaxial Cable
10 Mbps/baseband

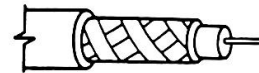

Fiber Optic Cable
200 Mbps

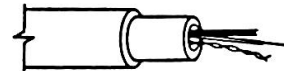

Twisted Pair Cable
Under 10 Mbps

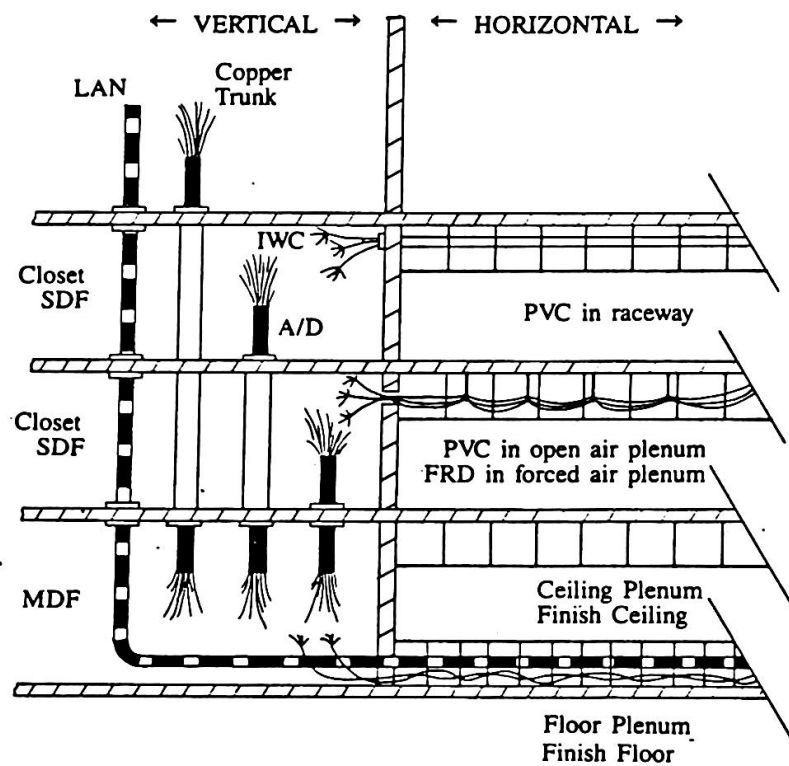
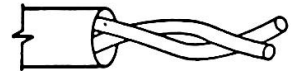

Bad Practice

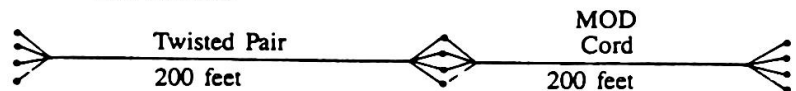

Accepted Practice

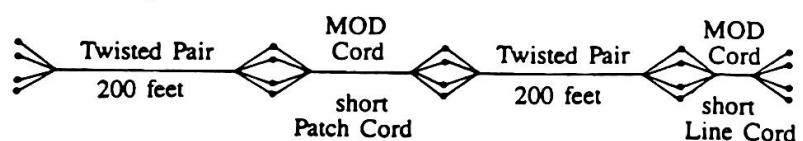

Cable and Cord 8.13

MOD Jacks

Outside shape and dimensions of jacks are equivalent to AT&T 641A series. 100 jacks per standard package. WE polarizations furnished with 6 inch flying leads of #26 AWG stranded conductors. 100 per standard package.



MOD Jack

MOD Plug

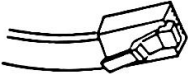

# Wires	Polzn	MOD Jack
4-wire	WE4W	01-004
6-wire	WE6W	01-006
8-wire	WE8W	01-008
8-wire	WE8K	01-009

Prewired Line Cords



MOD Cord

Cable is Western Electric (WE) style parallel-conductor modular cord.

Wiring feet	WE6R	WE6W	WE8W
Normal	1	05-551-0	05-661-0
	3	05-553-0	05-663-0
	5	S 05-555-0	S 05-665-0
	15	S 05-557-0	S 05-667-0
	25	05-558-0	05-668-0
Reverse	50	05-559-0	05-669-0
	15	S 05-557-1	S 05-667-1

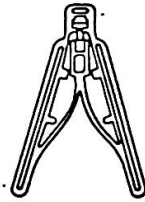

WE4N6 Tool
04-201
Crimps WE4W
and WE6W
plugs only.



MOD Tool
04-301
Crimps WE-W
and WE-R
plugs. Order
MOD Dies
separately.

MOD Cord

Western Electric (WE) style with PVC construction, silver satin jacket, #26 AWG stranded Cu parallel conductors. 500 feet per spool.

MOD Cord	IWC-PVC	IWC-FRD	MOD Plug	MOD Tool	Mod Die
S 03-316	S 39-103	39-203	S 02-555	04-301	04-305
S 03-316	S 39-103	39-203	S 02-556	04-301	04-306
S 03-318	S 39-104	39-204	S 02-558	04-301	04-308
S 03-314	S 39-102	39-202	S 02-554	04-301	04-306
S 03-318	S 39-104	39-204	02-559	04-301	04-308

MOD Plugs

Modular Plugs are crimped to the ends of modular cord or IWC cable. MOD Tool and Die required. 100 per standard package.

Line Cords are factory wired cable assemblies with a modular plug at each end. Line Cords can be wired Normal or Reverse.

Available in Modular Cord, IWC-PVC, and IWC-FRD cable constructions.

IWC-PVC

Cable is Inside Wire Cable (IWC) twisted pair cable. PVC construction.

IWC-FRD

Cable is Inside Wire Cable (IWC) twisted pair cable. FRD construction.

WE6R	WE6W	WE8W	WE6R	WE6W	WE8W
S 45-557-0	S 45-667-0	45-887-0	46-557-0	46-667-0	46-887-0
45-558-0	45-668-0	45-888-0	46-558-0	46-668-0	46-888-0
45-559-0	45-669-0	45-889-0	46-559-0	46-669-0	46-889-0
45-557-1	45-667-1	45-887-1	46-557-1	46-667-1	46-887-1

(Also available in 4W)

Cable

Prewired IWC

25-pair IWC is available Prewired with 50-position female connectors (C) and male plugs (P).

Feet	IWC-PVC	IWC-FRD
PC 10	S 40-110-12	40-210-12
	S 40-130-12	40-230-12
	S 40-150-12	40-250-12
	40-100-12	40-200-12
PP 1	S 40-101-11	40-201-11
	40-110-11	40-210-11
	40-130-11	40-230-11
	40-150-11	40-250-11
CC 1	S 40-101-22	40-201-22
	40-110-22	40-210-22
	40-130-22	40-230-22
	40-150-22	40-250-22
100	40-100-22	40-200-22

Running IWC

Standard put-up is 1000 feet on a disposable reel.

Pair Count	IWC-PVC	lbs/ Mft	OD in	IWC-FRD	lbs/ Mft	OD in
2	S 39-102	14	0.19	39-202	10	0.19
3	S 39-103	23	0.21	39-203	14	0.21
4	S 39-104	29	0.22	39-204	18	0.22
6	S 39-106	43	0.23	39-206	25	0.23
12	S 39-112	66	0.30	39-212	50	0.30
25	S 39-125	120	0.40	39-225	96	0.40

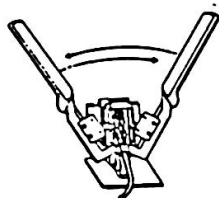

Butterfly Tool
40-010



Male Plug
S 40-011

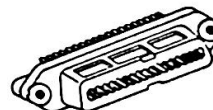

Female Connector
S 40-012

50-Positions

Use the Butterfly Tool to field wire these 50-position plugs and connectors to 25 pairs in one shot.

Allow approximately 1 pound shipping weight per 10 feet of cable.

8.14 MOD Adapters

MOD MOD

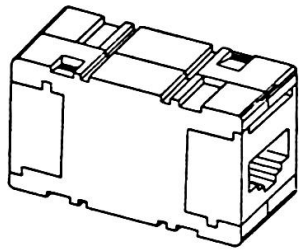

0 9 - T x x - A B C
Type -
(below)

Wiring

MOD Polarization
(see page 17)

0 blk	6 WE6W
1 BT4L	7 B T 6H
2 BT6L	8 WE8W
3 BT4H	9 WE8K
4 WE4W	MWE8M
5 WE6R	

MOD MOD Adapters are available in 8 combinations of 11 polarizations. Thousands of possibilities. Standard or special wiring.

MOD MODs may be installed free hanging, attached to a surface with tape, or field-mounted on a US1 Wall Plate or a 19 inch Punched Rack Panel. Plates and Panels include MOD MOD mounting Clips.

35-531	Double Sided Adhesive Tape
35-513	Velcro Tape Strips (10pr/pkg)
35-521	Adhesive Magnetic Tape (10pcs/pkg)
16-110	US1 Plate for 1 MOD MOD
16-210	US1 Plate for 2 MOD MODs
30-310	19 inch Panel for 16 MOD MODs
34-141	Mounting Clips (100/package)

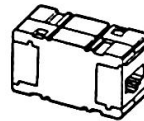

Coupling

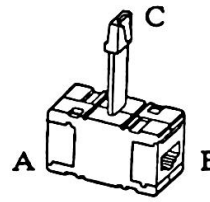

Tee

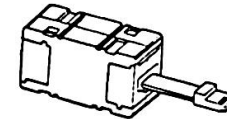

Reverse

Modular Polarization	Item	Normal	Reverser
6-wire WE6R	Coupling	09-200-550	09-201-550
	Tee	09-300-555	
	Reverser		09-101-550
6-wire WE6W	Coupling	09-200-660	09-201-660
	Tee	09-300-666	
	Reverser		09-101-660
8-wire WE8W	Coupling	09-200-880	09-201-880
	Tee	09-300-888	
	Reverser		09-101-880
8-wire WE8K	Coupling	09-200-990	09-201-990
	Tee	09-300-999	
	Reverser		09-101-990

Polarization Changers

Used to change a modular plug's polarization.

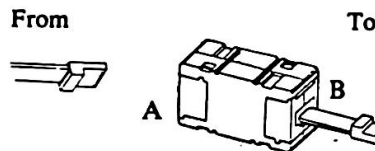

From	Wiring	To	MOD MOD Jack-Plug
WE6R	MODpin to MODpin	WE6W	09-104-560
WE6R	MMJ to STND	WE6W	09-100-560
WE6R	MMJ to 258A	WE8W	09-103-580
WE8W	MODpin to MODpin	WE6R	09-104-850
WE8W	STND to MMJ	WE6R	09-100-850
BT6L	BT to STND	WE6W	09-100-260
WE6W	STND to BT	BT6L	09-100-620

Couple
BT6L to WE6W
09-200-620

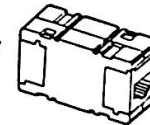

Type 1

Type 2

Type 3

Type 6

Type 7

Type 8

Jack Only
Type 9

Plug Only
Type 0

MOD Coupling

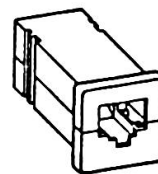

Each Coupling is furnished with a piece of double sided adhesive tape for mounting on a surface. Wired Normal.

Couplings are also available factory-mounted on Wall Plates and on 19 inch Rack Panels.

6-wire S 10-660	WE6W
8-wire S 10-880	WE8W

MOD Adapters 8.15

MOD Baluns

to adapt coaxial interfaces for operation with twisted pair cable. All Baluns are mounted on a modular WE6W jack and conform to FCC rules, computing equipment (Class A limits) sub-part J.

Good practice to use identical Baluns at both ends of a circuit. Mixing Baluns made by different manufacturers can cause problems if their impedances do not match.

Baluns are particularly sensitive to any impedance mismatch (page 8.12). Avoid mixing different gauges. Keep the amount of modular cord in the circuit to a minimum.

ETHERMOD A pair of ETHERMOD Baluns and one twisted pair may be used in lieu of an Ethernet Transceiver Cable for distances up to 250 feet. Two ETHERMODs per cord package.

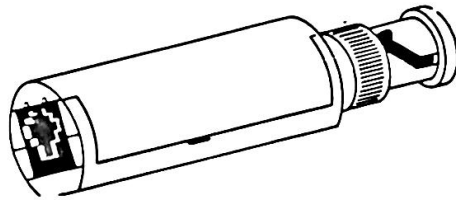

MONOMOD
S 41-624

A pair of MONOMOD Baluns and one twisted pair may be used in lieu of the coaxial cable run from an IBM 3270-class terminal to a controller. Operates at distances of up to 1200 feet (with up to 25 feet of modular cord in the circuit).

WANGMOD
S 41-634

A pair of WANGMOD Baluns and one twisted pair may be used in lieu of the dual coaxial cable required for Wang 2200, 4200, and 5500 terminals. Operates at distances of up to 900 feet (with 5 feet of modular cord in the circuit).

MINIMOD
S 41-614

A pair of MINIMOD Baluns and one twisted pair may be used in lieu of the twinaxial cable run to an IBM 5291 terminal. Operating distance (including 60 feet of modular cord) varies from 3500 feet for a single 5291 on a segment to 1500 feet for a segment with 6 terminals.

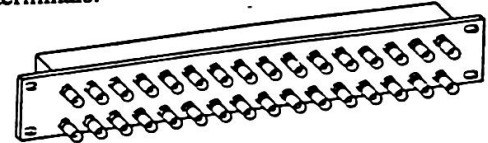

WANGMOD Panel
41-734-10

Panels are for 19 inch Rack mounting, each is 3-1/2 inches high (2 mounting positions). MONOMOD Panel contains 24 Baluns, WANGMOD has 16. Baluns are wired to a Male 50-position Plug.

MONOMOD Panel
41-724-10 (24 port)
41-744-10 (32 port)

Use 09-100-560 Polarization Changer to adapt a Balun for a WE6R Line Cord.

MOD IBM

Jack Style

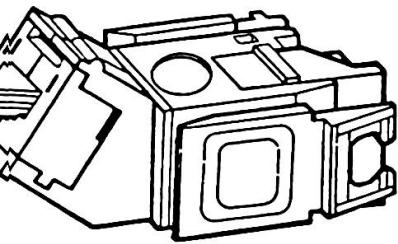

"The IBM Token Ring Network was designed for use with twisted-pair media . . . telephone media permits satisfactory operation under most circumstances."

from IBM's Telephone Twisted-Pair Media Guide (GA27-3714-0)

The Jack Style converts the IBM Data Connector into a modular jack. Used at IBM Wall Plates to attach a modular Line Cord or at Equipment such as the IBM 8228 MAU to attach an Octopus.

The Plug Style converts the IBM Data Connector into a modular plug. Used at Modular Wall Plate to attach an IBM Data Connector.

Modular polarization	Jack Style	Plug Style
WE6R	13-315-3	13-325-3
WE6W	use WE8W	use WE4W
WE8W	S 13-318	use WE4W
WE4W	use WE8W	13-324

MOD Dtype

MOD Dtype Adapters are used to adapt D subminiature connectors to a modular jack. They are available in 9-, 15-, and 25-size, male and female.

The MOD Dtype Adapters may be ordered as unwired individually packaged kits, wired to RS232 or RS423/232 standards (pages 22 and 23) or special wired to your specifications.

The standard Kit includes a slate shell with no logo, a set of 0.437 screws and saddles, a retainer clip (25-size only), a modular jack of specified modular polarization with flying leads crimped onto Dtype contacts and a Dtype connector of specified size and sex.

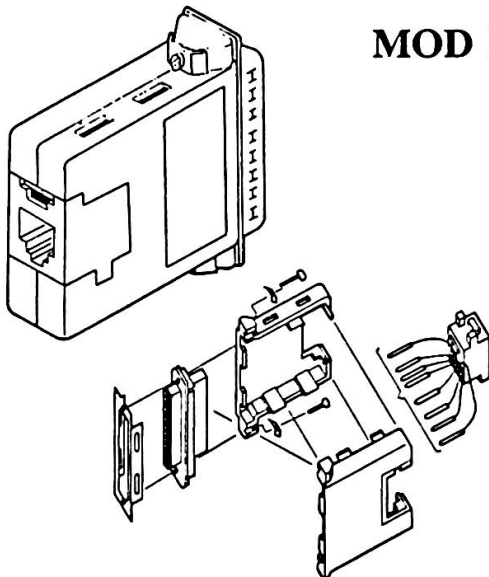

Mod Dtype Adapter Kit	WE6R		WE8W	
	Male	Female	Male	Female
25-size	06-885-999	06-985-999	S 06-888-999	S 06-988-999
15-size	07-885-999	07-985-999	S 07-888-999	S 07-988-999
9-size	08-885-999	08-985-999	S 08-888-999	S 08-988-999

8.16 Interfacing

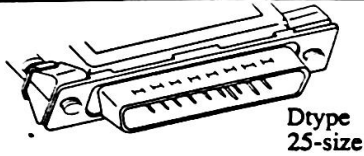

RS232

The EIA RS232 Interface was originally developed to provide for the attachment of a Data Communications Equipment (modem) to a Data Terminal Equipment (computer or data terminal) over a 25 lead cable wired straight-through end-to-end. The interface connector is a D subminiature (Dtype) 25-size.

RS232 has become the predominant twisted pair data interface. It is the standard by which most modems, computers, data terminals, multiplexers, data switches, and LAN Nodes are interconnected. The majority of this equipment uses only a subset of RS232's 25 leads. Asynchronous devices are usually wired with 4- or 6-wire channels supporting 2 data leads (DataIn and DataOut), 1 signal ground, and 0 to 3 control leads. These leads are criss-crossed and jumpered as required at the equipment connections within Interface Adapters.

RS232 specifies that the maximum distance between devices should not exceed 50 feet. In practice, RS232 has been known to perform at 9600 bps for distances of several hundred feet. The maximum distance depends primarily upon the quality of the equipments' RS232 driver/receivers and the data transmission speed between the equipment.

A MOD Driver is available to extend the allowable distance between RS232 DTE devices. It is linepowered, deriving power from RS232 DTR or RTS leads (Dtype pins 20 or 4). It is rated at 5 miles for data speeds up to 19.2 Kbps over two twisted unshielded #24 AWG pairs. Use the MDN unit at one end of the channel and the MDR unit at the other end. The MOD Driver does not pass any control signals.

RS232 Standard Adapters and Drivers

RS232 Standard Adapters may be used on any 4-, 6-, or 8-wire channel with WE4W, WE6W, or WE8W modular Polarization in either STND or 258A modular wiring Sequence. End-to-end wiring is Normal. (See pages 16 and 17).

Adapters are MOD Dtype, male or female 25-size, wired to a WE8W modular jack, 0.437 screw with saddle hardware (Driver has thumb screws), color coded shells.

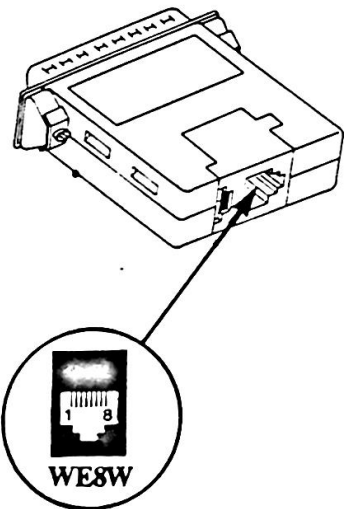

RS232 Standard for STND and 258A Sequence

Intended Application

DTE to DCE, all 25 leads straight-through

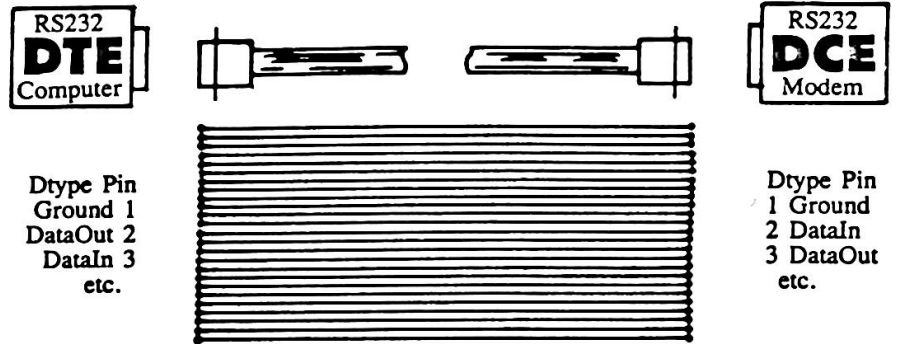

Accepted Practice

DTE to DCE, DTE to DTE, DCE to DCE, subset of leads jumpered and criss-crossed as required at ends

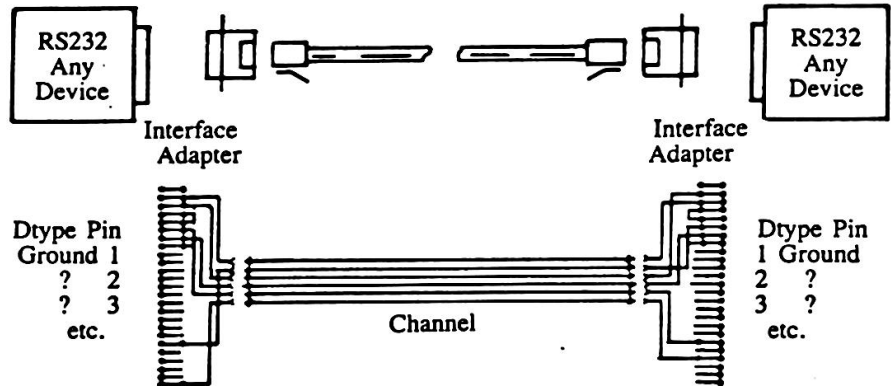

RS232 Standard Connectivity

To determine which Interface Adapter to use at an RS232 device first determine if the device receives DataIn on Dtype pin 3. If it does it is a DTE by definition. If it doesn't it is a DCE by definition. Then,

If the device is a DTE

If the device is a single channel Data Terminal specify DTEDRP. Otherwise specify DTESYS. For Drivers, MDN and MDR respectively.

If the device is a DCE

If device is to connect to equipment fitted with a DTESYS Adapter specify DC4SYS. Otherwise specify DC4DRP.

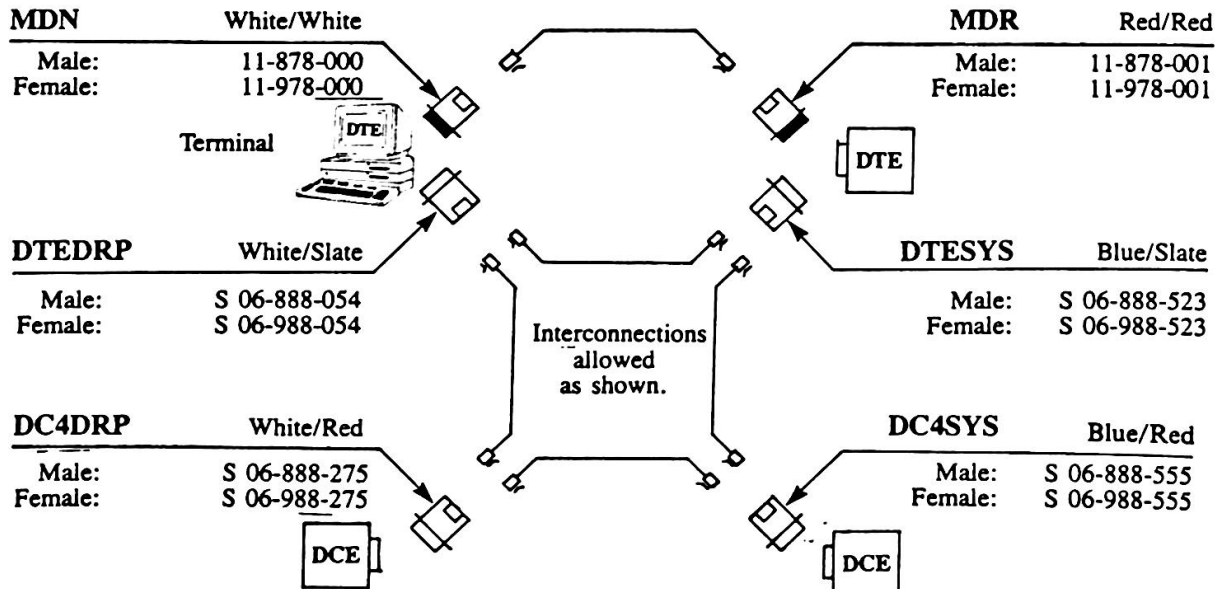

Interfacing 8.17

RS423/232 Standard for MMJ Sequence

RS423

The EIA RS423 Interface electrical specification offers a significant improvement over RS232's speed and distance limitations. Because RS423 is a balanced interface the effects of cross talk and external noise (see page 18) are minimized.

RS232 devices can connect to RS423 devices. If RS232 is passively adapted to RS423, electrical specifications of RS232 apply end-to-end. If RS232 is actively converted the RS423 specifications would apply.

Digital Equipment, Hewlett-Packard, and several data switch manufacturers offer RS423-interfaced equipment. They have not yet agreed upon a standard RS423 interface connector.

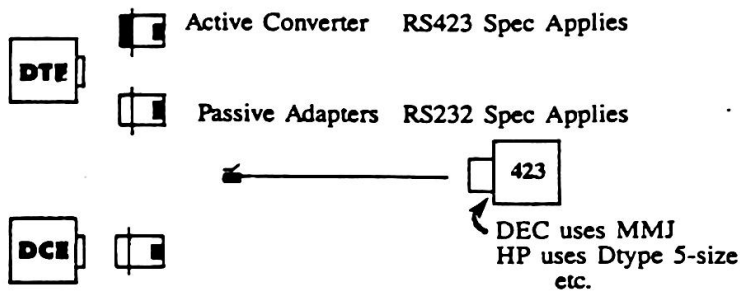

RS423/232

In 1986 Digital Equipment Corp. introduced a new modular Polarisation, WE6R, and a new modular wiring Sequence, MMJ. Data equipment wired with the WE6R is segregated from the WE4W, WE6W, and WE8W voice polarisations. The two are similar yet not mateable. Better yet, MMJ allows the intermingling of any manufacturer's RS232 or RS423 Interfaced Equipment over a simple connectivity standard.

Most RS232 or RS423 devices can be adapted to MMJ. The four data leads are mandatory, the two control leads are optional.

Any MMJ can be connected to any other MMJ provided there is one Reverse installed anywhere in the channel.

More than one Reverse may be installed. So long as there are an odd number of Reverses in the channel, the end-to-end result will always be Reverse.

The Reverse may be a reversing Line Cord, MOD Patch Cord, or MOD MOD Adapter. See pages 19 and 20.

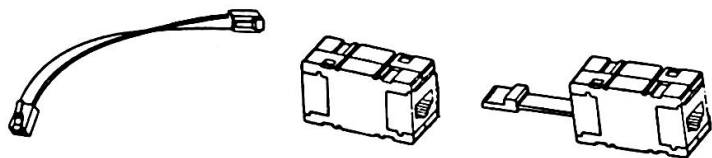

RS423 Equipment to MMJ		RS232 Equipment to MMJ	
WE6R Pin	RS423 Signal	WE6R Pin	RS232 Signal
1	ReadyOut	WPT 1	ReadyOut
2	DataOut+	BLK 2	DataOut
3	DataOut-	BLU 3	Signal Ground
4	DataIn-	GRN 4	Signal Ground
5	DataIn+	WEL 5	DataIn
6	ReadyIn	BLU 6	ReadyIn

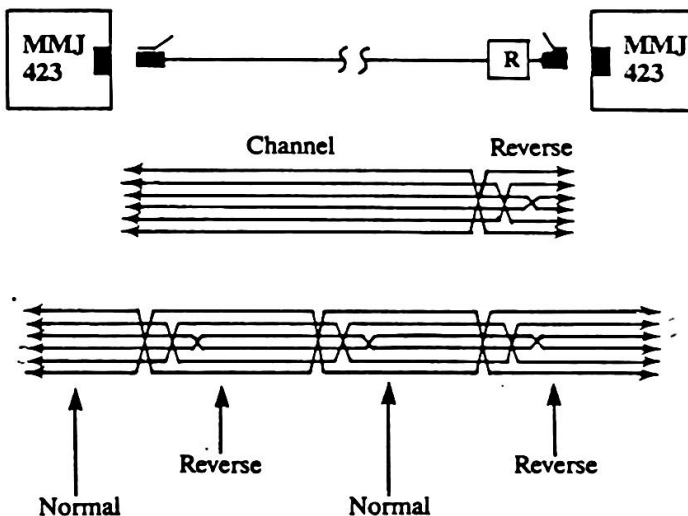

RS423/232 Standard Adapters and Converters

RS423/232 Standard Adapters and Converters may be used on 4- or 6-wire channels with WE6R modular Polarization and MMJ modular wiring Sequence. Adapters and Converters are wired Normal. End-to-end wiring is Reverse. (See pages 16 and 17.)

They are MOD Dtype Adapters, male or female 25-size, wired to a WE6R modular jack, 0.437 screw hardware (thumb screws on Converter), color coded shells.

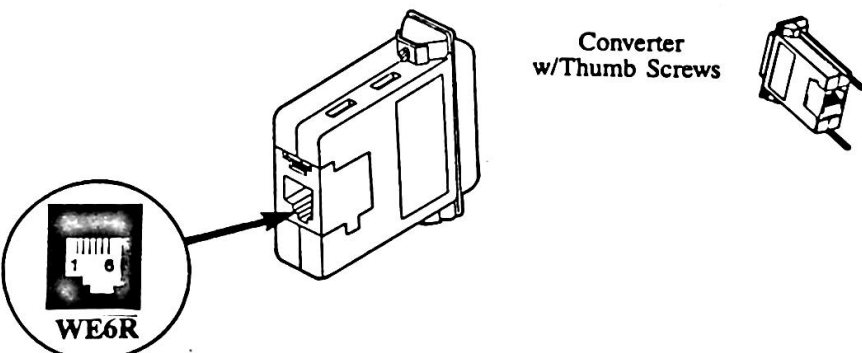

RS423/232 Standard Connectivity

For RS423 Devices: If the device has an MMJ no adapter is required. Otherwise see page 25.

For RS232 Devices: Determine if the device receives DataIn on Dtype pin 3. If it does it is a DTE by definition. If it doesn't, it is a DCE by definition. Then,

If the device is a **DTE**

Specify Passive Adapter
White/Slate

Male: 06-885-DTE

Female: -06-985-DTE

or

Specify Active Converter
White/White

Male: 11-875-TCN

Female: 11-975-TCN

If the device is a **DCE**

Specify Passive Adapter
White/Blue

Male: 06-885-DCE

Female: 06-985-DCE

Anything can connect to anything so long as the end-to-end channel is Reverse.

8.18 Interfacing

Multiple Channel Connectors

Several manufacturers offer multiple channel connectors on their equipment for direct attachment of 25 pair Feeder Cables. Since there is no accepted convention for RS232 signal assignments on a 50-position the pinouts on the equipment connector vary from one manufacturer to another.

A CrossWye adapts any equipment's Interface pin-out to a Wiring System standard to simplify equipment cross connections at a Distribution Frame.

Standard CrossWyes are compatible with the RS232 and RS423/232 Standards on page 8.16 and 8.17. Special wiring is available.

CrossWye Specification

If you are using MMJ modular wiring Sequence with RS423/232 Standard Adapters (page 8.17) specify CrossWye from the table as Base + NORMAL suffix.

If you are using STND or 258A modular wiring Sequence with RS232 Standard Adapters (page 8.16) specify CrossWye as Base +

DC4DRP suffix if other ends of channels are fitted with DTEDRP or DC4SYS Adapters, or DC4SYS suffix if other ends of channels are fitted with DTESYS Adapters.

STND to 258A Converters (below) are attached between the Cross Wye and Feeder if Drops are wired with 258A Sequence.

Manufacturer Interface	(#xNw)	Fig	(#xNw)	CrossWye Base	MMJ NORMAL + suffix	STND DC4DRP suffix	STND DC4SYS suffix
Gandalf GLM528 RS232	(8x6w)	B	(8x6w)	37-215-11	-013	-310	-410
PACX 2000 RS232	(8x6w)	B	(8x6w)	37-215-31	-013	-310	-410
ASM 2081/MT2	(8X6w)	B	(8X6w)	37-215-41	-013	-310	-410

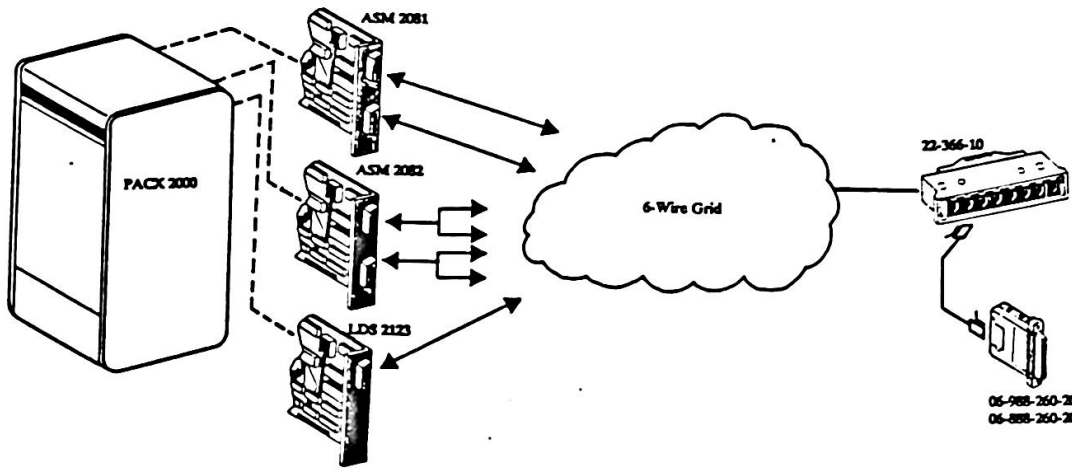

50-position sex on manufacturer's equipment is female (F) unless otherwise noted. (#xNw) indicates number of channels (#) per 50-position and the number of wires per channel (N) on Equipment and Feeder sides of the CrossWye assembly.

STND to 258A Converters

Adapt any STND Sequence CrossWye to operate over 258A Sequence wiring.

37-301-42-911 4-wire STND on CrossWye to 8-wire 258A on Feeders.

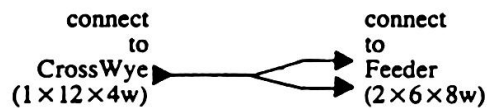

37-701-62-911 6-wire STND on CrossWye to 8-wire 258A on Feeders.

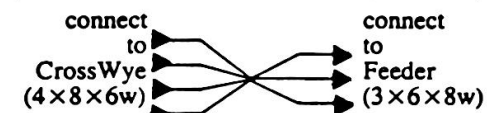

37-201-82-911 8-wire STND on CrossWye to 8-wire 258A on Feeders.

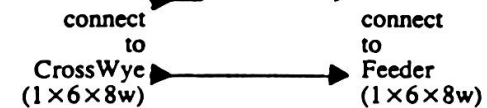

Typical cross connect without CrossWye



Typical cross connect with CrossWye

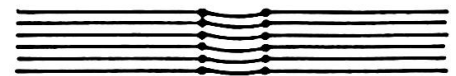
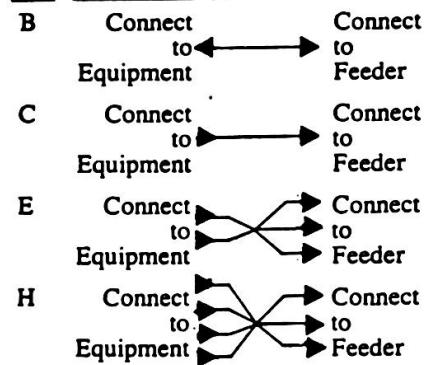

Fig Reference Figures



Channel Changers

Adjust the number of wires per channel on any CrossWye or other Male 50-position Plug.

37-708-62-91 8-wire channels on CrossWye to 6-wire channels on Feeder.

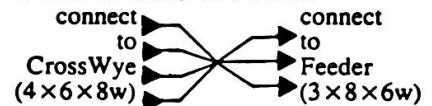

37-504-62-91 4-wire channels on CrossWye to 6-wire channels on Feeder.

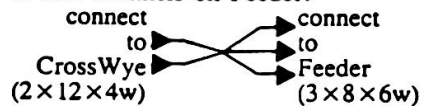

Reverser

Performs the equivalent of an MMJ modular Reverse on a 25 pair cable.

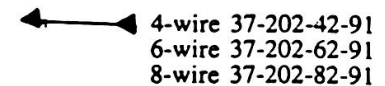

See also Feeder Cables and 50-position sex changers on page 8.13

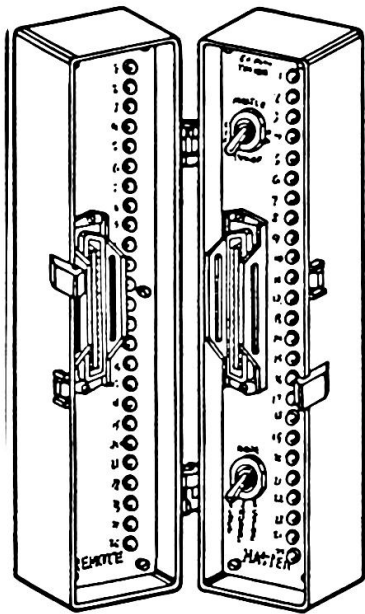

Big Tester
S 33-299

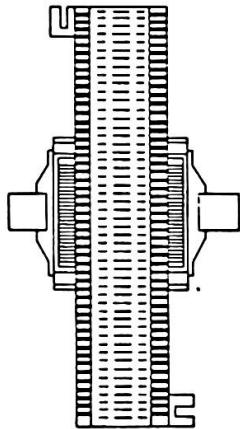

Breakout
33-211

The Big Tester indicates wiring errors on 25 pair cables or binder-groups. The continually sequencing LED display provides indication of any shorts, opens, or miswires among any of the 25 pairs under test.

The Master and Remote units snap apart for the end-to-end testing of installed cables. Both are wired with male 50-position plugs.

Frame Shoes are available for quick connection of the tester to 66M Blocks, MOD Patch Panels, Northern Telecom BIX Blocks, AT&T 110 Blocks, and Krone Blocks. Frame shoes are wired with a female 50-position connector.

The Big Tester is powered by a 9 volt battery (included).

The 50-position Ribbon Cable is 10 feet long with a male and a female 50-position at each end.

The 50-position Breakout is used to access individual conductors at a 50-position. Includes 50 Bridging Clips and 10 Clip Leads.



Ribbon Cable
S 33-255

Feeder Test Setup

Distribution Frame



Frame Shoes

MOD Patch Shoes

Assemblies of modular plugs spaced to quick fit the front panel modular jacks on MOD Patch Panels.

Wires /chnl	Modular Polzn/Seq	MOD Patch Shoe
2-wire	WE4W/STND	33-224-20
4-wire	BT4L/BT	33-241-22
4-wire	WE4W/STND	33-244
6-wire	BT6L/BT	33-242-22
6-wire	WE6R/MMJ	33-245-23
6-wire	WE6W/STND	33-246
8-wire	WE8W/STND	33-248
8-wire	WE8W/258A	33-248-21

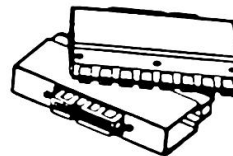

Other end of Feeder

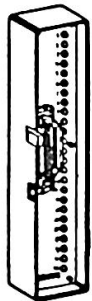
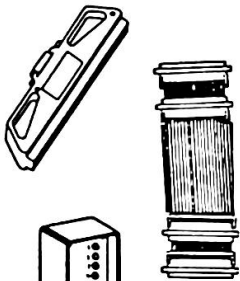
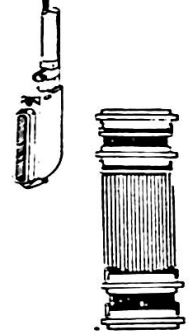

Master Unit

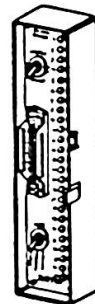

8.20 Testers

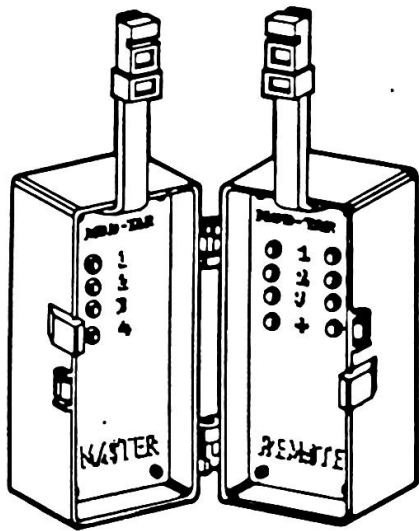

Little Tester
S 33-099

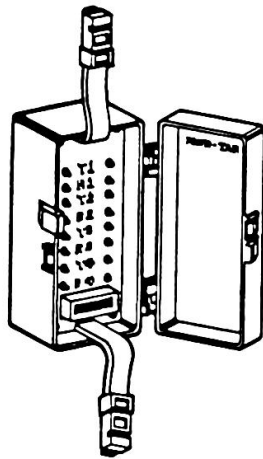

Breakout
S 33-103

Cable Kit
33-164
(see page 15)

The Little Tester indicates wiring errors on 2-, 4-, 6-, and 8-wire channels. The continually sequencing LED display provides indications of any shorts, opens, or miswires among any of the conductors under test.

The Master and Remote units snap apart for the end-to-end testing of installed cables. Both are wired with a modular plug. Two modular couplings are included.

The Little Tester will verify wiring integrity of most cabling systems. A specific kit may be required.

Frame Adapters are available for connection of the tester to 66M Blocks, MOD Patch Panels, Northern Telecom BIX Blocks, AT&T 110 Blocks, and Krone Blocks.

Test Taps adapt the tester to any modular polarization or sequence. Two taps per standard package.

The Little Tester is powered by a 9 volt battery (included).

The cable kit consists of two 10 foot cords and two modular tees.

The modular Breakout is used to access individual conductors at a modular jack or plug. Two modular couplings are included.

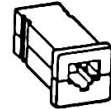

Drop Test Setup

Distribution Frame

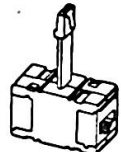
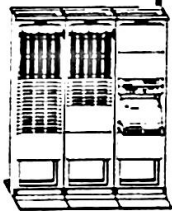

Test Tap

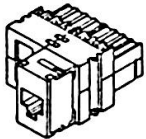

Frame Adapters

66M

66M Frame Adapter

#Wires /chnl	Modular Polzn/Seq	66M Adapter
4-wire	WE4W/STND	33-124
4-wire	BT4L/BT	33-124-22
6-wire	WE6W/STND	33-126
6-wire	BT6L/BT	33-126-22
6-wire	WE6R/MMJ	33-126-53
8-wire	WE8W/STND	33-128
8-wire	WE8W/258A	33-128-81

Test Taps

#Wires /chnl	Polzn/Seq	Test Tab
4-wire	WE4W/STND	33-165
4-wire	BT4W/BT	33-166
6-wire	WE6R/MMJ	S 33-163
6-wire	WE6W/STND	33-165
6-wire	BT6L/BT	33-166
8-wire	WE8W/258A	S 33-162
8-wire	WE8W/STND	33-165

Drop

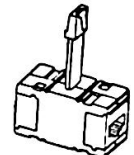
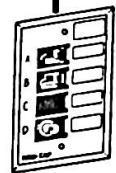

Test Tap

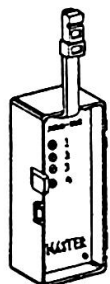

Master Unit

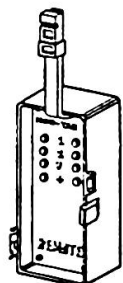

Remote Unit

Testers 8.21

The Blue Tester is used to monitor RS232 Interface signals at a D subminiature (Dtype) 25-size plug.

LEDs indicate Interface On status of Dtype pins 2, 3, 4, 5, 6, 8, 20, 22, and 25. (Interface signals DTE transmit data, DTE receive data, Clear to Send, Request to Send, Data Set Ready, Carrier Detected, Ring Indicator to DTE, and Ring Indicator to DCE, respectively).

The Blue Tester is line powered.

The 25-size Ribbon Cable is 10 feet long with a male and a female 25-size at each end.

The 25-size Breakout is used to access individual conductors at a 25-size. Includes jumper leads.

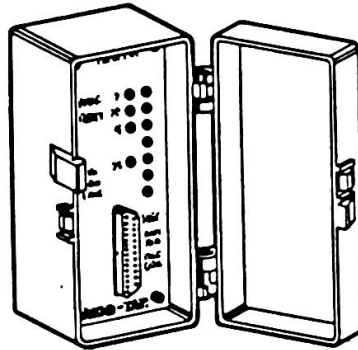

Blue Tester
33-301

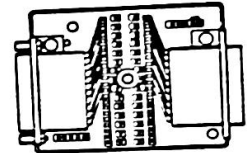

Breakout
33-311



Ribbon Cable
33-355

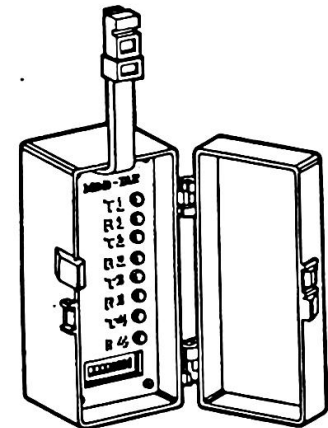

White Tester
33-330

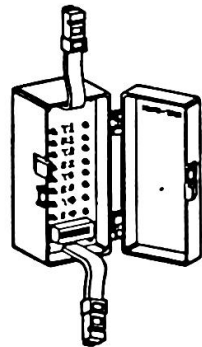

Breakout
S 33-103

The White Tester is used to monitor RS232 and RS423 Interface signals at a modular jack or plug. A modular coupling is included.

LEDs indicate Interface On status of each modular pin.

The White Tester is line powered.

Frame Adapters are available for quick connection of the tester at 66M Blocks, MOD Patch Panels, Northern Telecom BIX Blocks, AT&T 110 Blocks, and Krone Blocks. See page 13.

Test Taps adapt the tester to any modular polarization and sequence. Two taps per standard package.

The Cable Kit consists of two 10 foot cords and two modular tees.

The modular Breakout is used to access individual conductors at a modular jack or plug. Two modular couplings are included.

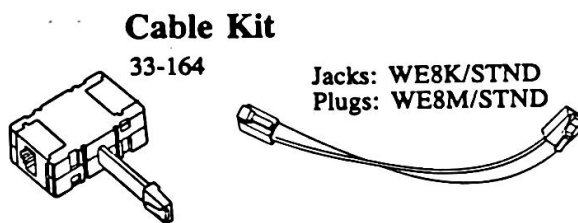

Cable Kit
33-164

Jacks: WE8K/STND
Plugs: WE8M/STND

# Wires/ Channel	Polzn/Seq	Test Taps
4-wire	WE4W/STND	33-165
4-wire	BT4W/BT	33-166
6-wire	WE6R/MMJ S	33-163
6-wire	WE6W/STND	33-165
6-wire	BT6L/BT	33-166
8-wire	WE8W/258A S	33-162
8-wire	WE8W/STND	33-165

8.22 Functional Characteristics

1. **Cables** Pages 8.06, 8.12
 - 1.1. Horizontal Feeder Cables, Home Runs, and Drop Runs are twisted-pair Inside Wire Cable (IWC), PVC or FRD construction. Standard cables are unshielded. Cable with overall shield is available.
 - 1.2. Vertical Trunk Cable, if any, is twisted-pair Aerial/Duct (A/D) Cable, PVC construction with overall shield.
 - 1.3. Vertical and Horizontal Local Area Network, if any, is cabled to the particular vendor's specification.
2. **Channels**
A channel is the information path between two devices. Twisted-pair channels may be 2-, 4-, 6-, or 8-wire (1, 2, 3, or 4 pair).
3. **Cross Connect** Page 8.02
 - 3.1. Cabling is terminated and channels are cross connected on Distribution Frames.
 - 3.2. Standard cross connect apparatus is 66M Blocks and/or Modular Patching, 19 inch Open Bay Rack mounted. Wall mountings are available.
 - 3.3. The Gandalf System is also compatible with most other cross connect apparatus including ATT 110 Blocks, Northern Telecom BLX Blocks, and Krone Blocks.
4. **Horizontal Wiring** Pages 8.06, 8.08
 - 4.1. Drops are single channel attachment points to the Horizontal Wiring for Data Terminals and Telephone Sets.
 - 4.2. Demountable Drops are used with modular furniture systems and for temporary hook-ups. A Feeder Cable is run from a Distribution Frame to each furniture island. Feeder, Harmonica, Drop Run, and Drop snap together, snap apart.
 - 4.3. Wall Plates are installed in fixed-wall offices, each Plate has a Home Run cable to a Distribution Frame.
 - 4.4. A Drop Set is used to attach equipment to a Drop or Wall Plate. It consists of a Line Cord and, for Data Terminals, a MOD Adapter.
5. **System Connects** Pages 8.06, 8.18
 - 5.1. Systems are equipment with multiple channels such as Computer front ends, LAN Nodes, Voice Switches, Data Switches, Multiplexers, and Modem clusters.
 - 5.2. Equipment with a LAN interface is connected directly to the LAN to the particular vendor's specification.
 - 5.3. Other System Equipment is cabled to a Distribution Frame using Feeder Cables.
 - 5.4. Feeders direct connect to most Voice equipment Interfaces.
 - 5.5. Feeders are connected to Data equipment Interfaces with an Octopus and MOD Adapters or with a CrossWye.
6. **Data Interfaces** Page 8.18
 - 6.1. MOD Adapters adapt single channel Data Interfaces to the wiring system Basic Standard. CrossWyes adapt multiple channel Data Interfaces to the Basic Standard.
 - 6.2. Data Interfaces include EIA RS232, RS422 and RS423, Digital DECconnect RS423/232, IBM 3270, 5291 and twisted-pair Token Ring, and Wang 2200, 4200 and 5500.
7. **Wiring System Basic Standard** Page 8.10
The Wiring System can be configured with either Universal or Dedicated channels. For Universal channels one modular Polarisation is provided at all Drops. For Dedicated channels one modular polarisation is provided for Voice Drops and another compatible, yet non-intermateable, Polarisation is provided for Data Drops.
8. **Standard Modular Polarisations** Page 8.10
6-wire, WE6R Polarisation, MMJ modular wiring Sequence, used for Dedicated Data. Direct connect compatible with Digital DECconnect.
6-wire, WE6W (USOC RJ11), STND Sequence, used for Voice or Data, direct connect to Northern Telecom, Rolm, and most other Voice equipment.
8-wire WE8W (USOC RJ45), 258A Sequence, used for Voice or Data, direct connect to AT&T 258A equipment.

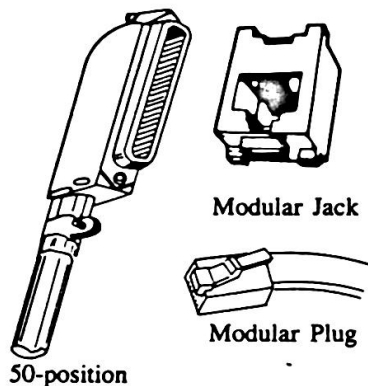

50-position
Modular Jack
Modular Plug
Any twisted pair connector, even the monster illustrated on the right, can be adapted to either 50-position or Modular.

Drawing Courtesy of Phil Frank.



VERTICAL WIRING

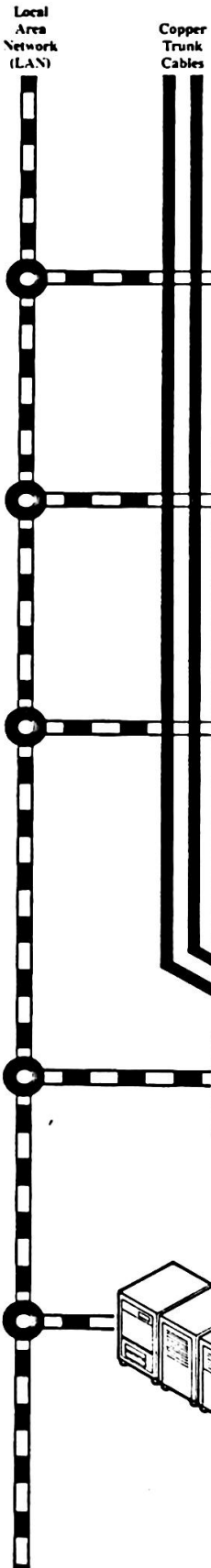

CROSS CONNECTS

Horizontal Wiring channels are connected to either LAN channels or Trunk Cable pairs on closet Sub Distribution Frames (SDFs).

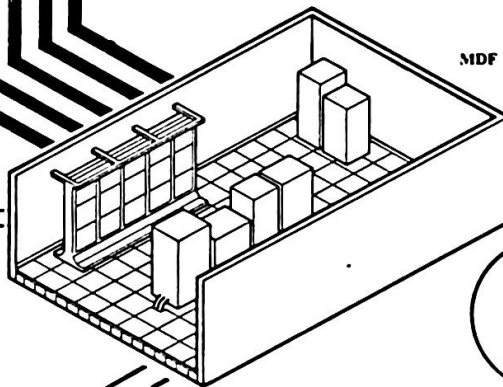
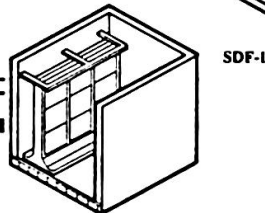
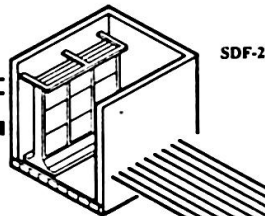
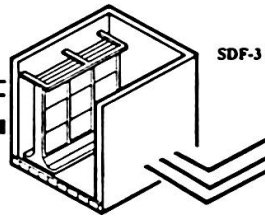

HORIZONTAL WIRING

Demountable Drops for Modular Office Furniture

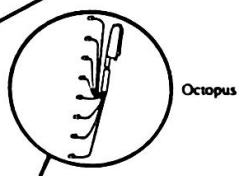
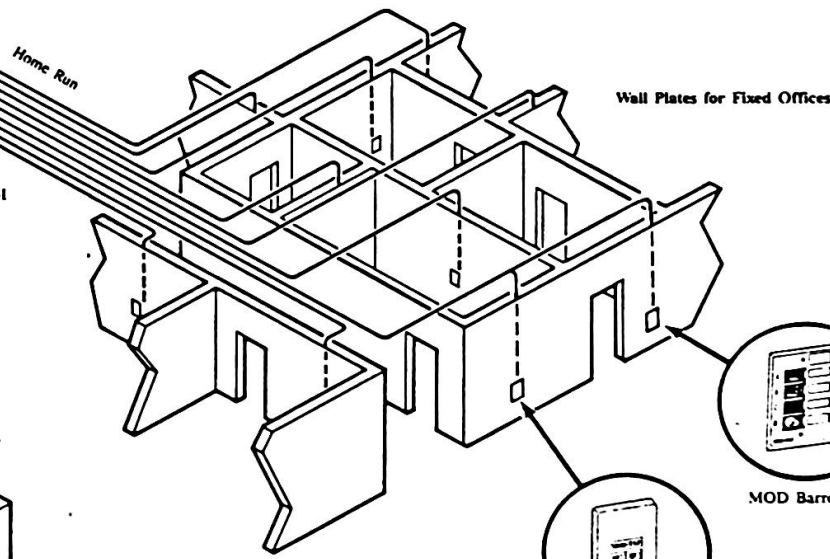
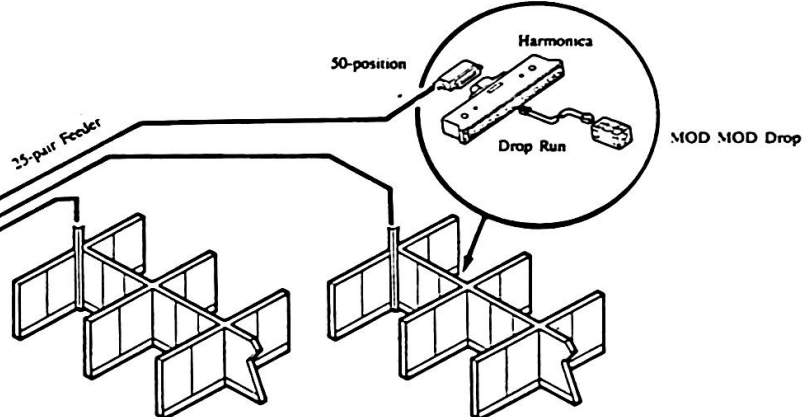

SYSTEM CONNECTS

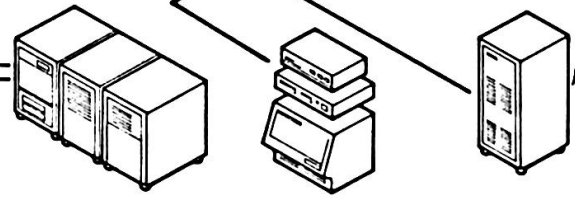

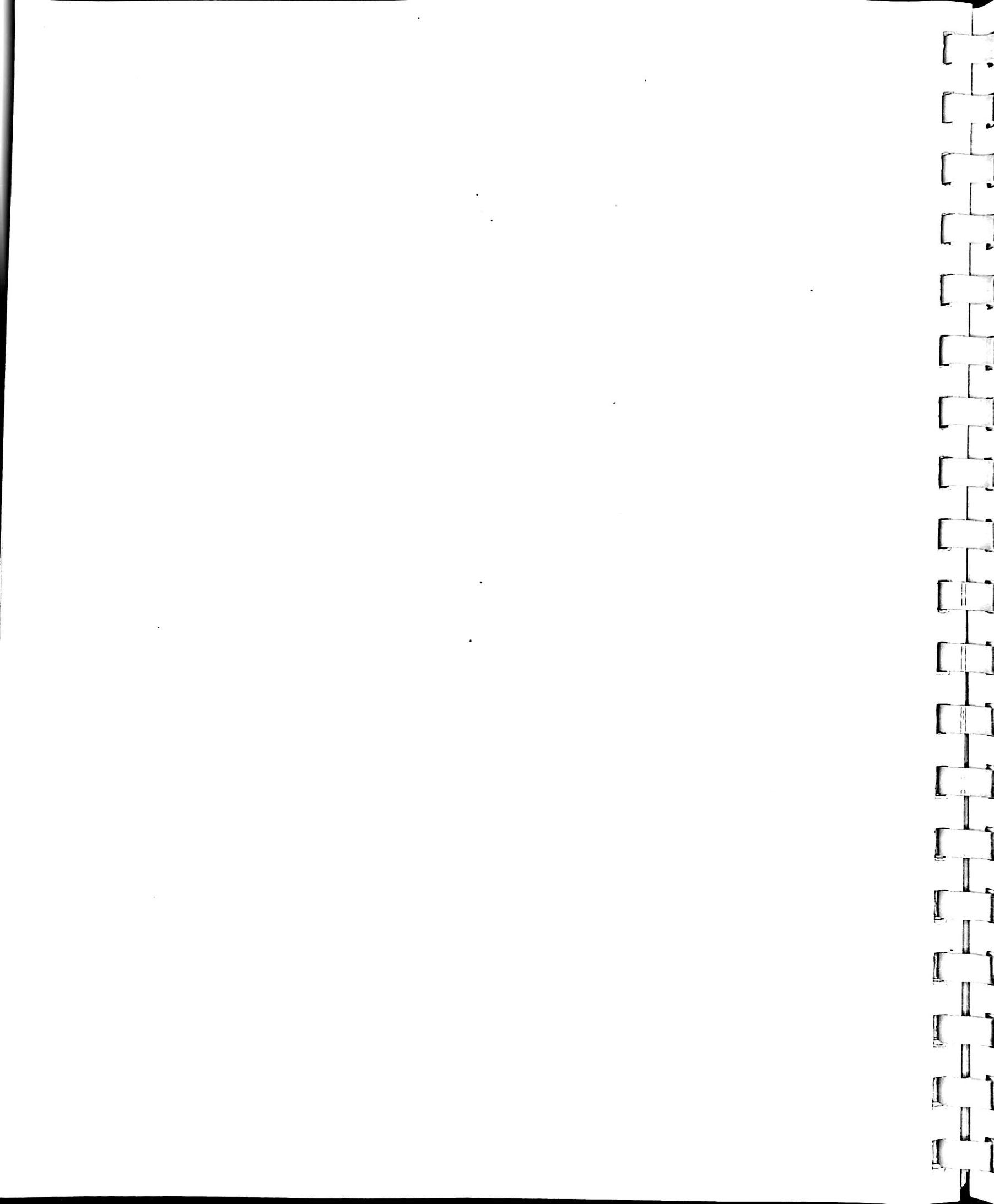

DATA NETWORKING

WIRING SYSTEM

With today's advances in technology, many various products are being linked together to form a network. Often, because of incompatibilities, different cabling is required in a single network to tie all systems together. However, progress is being made in this area of networking. This application note was instigated when interest was expressed in having PBX and digital transmission systems share common cabling.

One of the major concerns with digital transmission systems sharing a multipair cable is crosstalk interference generated by the various systems within the cable. The problem is then multiplied when sharing systems include analog (voice) PBX signals.

NATURE OF THE CROSSTALK INTERFERENCE

In any given cable, the crosstalk path between any two pairs of wire is dependent upon the nature of the insulating materials, the geometry of the wire pairs, and the electrical termination. For any two pairs, the amplitude and the phase characteristic of the crosstalk loss will not only vary with frequency, but will also be different for dissimilar pair combinations. Within one 25-pair binder group, there are 300 completely disparate crosstalk paths which may be characterized by 300 different transfer functions. The situation is correspondingly worse for larger cables. Furthermore, the crosstalk interference is dependent upon the frequency of most interest. This is usually taken to be a frequency near the center of the passband for the equalizer in the disturbed system under consideration. In addition, the disturbing transmissions can be bursty and unsynchronized with respect to one another as well as with respect to disturbed service.

In summary, the crosstalk interference problems in the common multipair cable can be classified into two major groups:

- 1) Internal to the cable - gauge, insulation, number of twists per foot.
- 2) External to the cable - terminating equipment and its termination impedance, longitudinal impedance, longitudinal balance, metallic and longitudinal spectrum of the signal and CMRR (Common Mode Rejection Ratio).

Having balanced transmitters prevents generating longitudinal signals, and having well-balanced receivers with high CMRR prevents longitudinal signals from being received.

OBJECTIVES

The subject of crosstalk has been studied extensively in the past. All of these studies assumed crosstalk in the cable with ideal terminating equipment. This paper will characterize Gandalf transmission products which terminate the cable and put them into three different categories:

- 1) *safe transmission products* - can be mixed with each other and analog PBX lines.
- 2) *special care products* - special care or restriction required when mixing with other safe transmission products.
- 3) *special wiring required* - no sharing possible.

GANDALF TRANSMISSION PRODUCTS

The analog PBX and the Central Office equipment are, in most cases, the main distributing system. Its control signals, ringing and DC voltage/current are not balanced with respect to ground. These signals can generate, when switched (start and end of ringing, OFF/ON hook), up to ± 130 V peak longitudinal signal (impulse noise) in the frequency range of up to 0.5 MHz.

When the analog PBX and digital transmission products are sharing common cabling, the main requirement on the transmission equipment is having longitudinal balance and CMRR very high for common mode signals up to ± 130 V. The only device which can handle this requirement is a transformer. Gandalf has always stressed this requirement and all its transmission products have transformer coupling. All non-transformer coupled devices can handle common mode signals only up to its power supply voltage (approximately ± 12 V).

A) Safe Transmission Products

Products: LDS 120, LDS 120A, mLDS 122, mLDS 123, mLDS 126, LDS 309, LDS 309A, smLDS 349, LDS 720, SAM 24, ACCESS 24, ACCESS 24S, ACCESS 24A, SAM 201, LDM 444, LDM 454, LDS 409 and all derivatives in PACX 4 or P2K or 3000 Rack Mount.

All group A products have transmit levels below 0 dBm and meet either AT&T Pub 43401 or DOC CS-03 or FCC part 68 which require safe levels of longitudinal balance and longitudinal signal levels. These products can share common cable without any significant performance degradation.

B) Special Care Products

Products: LDS 260, RM 3260, LDS 640 RM 3640, GLM 510, GLM 518, GLM 2518.

The products in group B do not comply with any regulations. They can be mixed with all products from group A provided the cabling consists of twisted pairs. Sharing common cabling with analog PBX lines should be avoided. Problems could arise in both the data transmission errors and unwanted noises in the analog lines particularly on longer distances.

Note: There is a special wiring procedure for DOV 640 connections.

C) Special Wiring Required

Products: T-1

These products have special wiring requirements which will be part of the manual (see note in group B).

gandalf

12/87
PRINTED IN CANADA

Subsidiaries of Gandalf Technologies Inc.

Gandalf Data Limited,
100 Colonnade Road
Nepean, Ontario, Canada
K2E 7M4
Tel: (613) 226-6500
Tlx: 053-4728

Gandalf Data, Inc.
1020 S. Noel Avenue,
Wheeling, Illinois 60090
Tel: (312) 541-6060
TWX: 910-651-4951

Gandalf Digital
Communications Ltd,
19 Kingsland Grange,
Woolston
Warrington, Cheshire
WA1 4RW England
Tel: (0925) 818484
Tlx: 629494

Gandalf Nederland B.V.
Kabelweg 37
1014 BA Amsterdam,
Holland
Tel: (020) 867611
Tlx: 15694

Gandalf Pacific Pty Ltd
Chatswood Village
Unit 4, 47 Neridah St.
Chatswood, N.S.W.
2067 Australia
Tel: 61-2-419-5977

FACTORY / FIELD SERVICE

Gandalf maintains fully equipped service facilities at all of its major locations. As well, Field Service personnel are available for on-site service and maintenance on an as-required basis. In many areas, service contracts can be arranged to suit specific requirements for availability and response time. For detailed information, please contact your nearest Gandalf office or representative.

ADDRESSES

Gandalf Data Limited

130 Colonnade Road South, Nepean, Ontario, K2E 7J5, (613) 723-6500

Gandalf Data, Inc.

1020 South Noel Ave., Wheeling, Illinois, 60090, (312) 541-6060

Gandalf Digital Communications Limited

19 Kingsland Grange, Woolston, Warrington, Cheshire, WA14RW, (0925) 818-484